

# EIS

## APPARATUS REPAIR



# 2024

# EIS

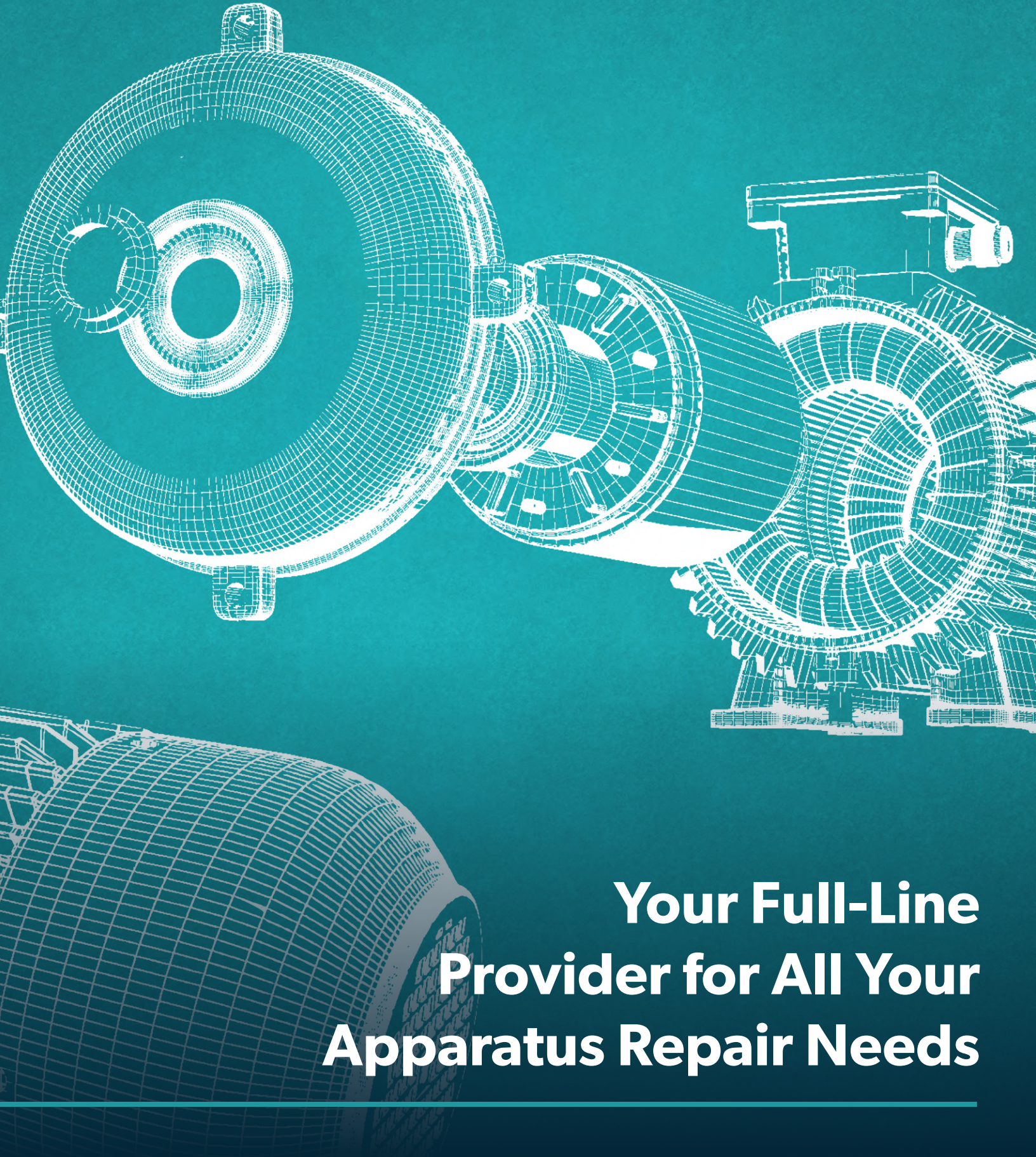

**Your Full-Line  
Provider for All Your  
Apparatus Repair Needs**

---

# TABLE OF CONTENTS

## EQUIPMENT

Alignment	32,35
Bake Ovens	7
Balancing	36
Bearing Tools & Accessories	31-35
Burn Off Ovens	4-6
Cleaning, Washing, Blasting	9-10
Commutator Equipment	37
Cut Off, Coil Cutter	10
Dyno	38
Hand Tools	21, 30
Paper Cutters	28-29
Paint Booth	36
Pullers	26
Rotor Totors	39
Test Equipment	17-24
Welding, Brazing, Soldering	24
Winding	11-16

## SUPPLIERS

ACE-Benko	4, 11
Benko Products	7
Better Engineering	10
AEMC	17
AW Dynamometer	38
Blast-It-All	9
Burndy	30
Campbell-Randall	29
Crown	14, 20-21, 28, 31
Eco Burn Off Ovens	8
Dyna-Bal	36
ELANTAS	6
Em-Quik Sleeve	25
Frontier Supply	39
Guspro/Bayco	5
HeatTek	4
H2Oweld	24
Hofmann	36
Industrial Pulley Puller	26
Isolex	30
Laycock Systems	15, 21

Lenni Products	28
Martindale Electric Co.	37
MBM	29
MDS/Schleich	18
Megger Instruments	23
Megger Baker Instruments	22-23
Nachi	34
NTN	33
Phenix	19-20
Posi-Lock	26
Rea	13
Remgrit	10
Schaeffler	31-32
Scheiing	12,14,30
S&W	14, 16
SKF	35
SprayTech	36
Steelman Industries Inc.	5,7
Tennsmith	28
Turner	10

# MAKING the **BEST** SERVICING the **REST**



## VPI • VOI • Batch Ovens for Motor Repair Excellence

### BURN OFF OVENS

The new ACE (RT) Radiant Tube Heat Cleaning Ovens are big on performance and have the ultimate in energy savings, about 20% over convection-only burn-off ovens. ACE introduces the radiant tube heater, which for the first time utilizes radiant plus convection heat. Heat from the radiant tube results in a consequent heat extraction efficiency of 90%. Heats even in the harshest environment.

- Ace hybrid heating design - (RT) system consists of a radiant tube, which directs the radiant energy upward
- Heat clean without pollution - Conforms to tough EPA air emission standards
- 11 gauge steel and coated with a high temperature, rust resistant paint
- 4" of high temperature insulation rated at 2,300° F (1,260° C) lines the oven
- Self-supporting exhaust stack to offer maximum energy efficiency
- Door is securely sealed by husky cam type latching mechanisms located on the top and bottom of the door, designed to accept a lock, as the door should not be opened during the heating cycle
- One touch control (OTC) automatic self-adjusting control system

**ace** BENKO PRODUCTS  
ENGINEERED TO BE MORE



EIS #	INSIDE DIMENSIONS			OVER CART		OUTSIDE DIMENSIONS	
ACE230-RT	36	36	47	33	56	64	58
ACE245-RT	60	60	72	57	80	94	85

Additional sizes available

## BURN OFF OVENS

- Automatic Process Control (APC)
- Unique Top/Down Heating Design - Creates more uniform temperatures, controls of hottest spot in the oven to prevent part damage and increases efficiency. It makes the process easier to control, lowers particulate emissions, allows ash pans in the bottom of carts, and cart wheels last much longer
- Exhaust kits include 14 linear feet of exhaust stack over the top of the oven, rain cap, and flashing (Additional stack lengths, elbows, dampers and other accessories are available from the factory)
- Meets NFPA/FM/UL Standards (Other standards by Industrial Risk Insurers (IRI), Canadian Gas Association (CGA), etc., can be substituted at small charge)
- High Fire Afterburner is standard with every oven, allowing the afterburner to rapidly heat up and maintain a minimum of 1,500°F during operation
- Cool-Down Circuit - If the afterburner fails for any reason, the water sprays are activated to cool the load to prevent smoke from going up the stack
- Automatically shuts off when oven is cooled
- The best quality and technological innovations in a wide variety of ovens to fit any situation and budget

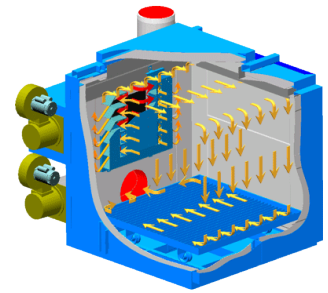

EIS #	INTERIOR DIMENSIONS			VOLUME INSIDE (FT <sup>3</sup> )
	WIDTH (IN)	DEPTH (IN)	HEIGHT (IN)	
STEELMAN343BAE	36	36	48	36
STEELMAN444BAE	48	48	48	64
STEELMAN666BAE	72	72	72	216
STEELMAN888BAE	84	84	84	512

Additional sizes available

## BURN OFF OVENS

- Modular U-shaped firebox
- Hinged cart track extensions
- V-Grooved cart wheels with hinged cart tracks
- High/low modulating process burner
- OTS (Over Temperature Suppression) system
- Electric door lock
- Advanced programmable control system
- Digital data logger



EIS #	USEABLE OVER CART TDIMENSIONS INSIDE CLEAR DIMENSIONS	INSIDE DIMENSIONS W X D X H (IN)	DESIGN LOAD CAPACITY (LBS)	LOAD CAPACITY (LBS)	THERMAL OXIDIZER CAPACITY (LBS/HR)	FUEL REQUIREMENTS 6'-8' WC NATURAL GAS		APPROXIMATE SHIPPING WEIGHT (LBS)
	W X D X H (IN)					MAX CFM	AVERAGE USAGE CFH	
GUS242424	24 x 24 x 24	28 x 28 x 38	800	3,600	10	400	240	3,700
GUS606060	60 x 60 x 60	66 x 68 x 87	4,000	8,000	50	1,500	900	10,800
GUS727272	72 x 72 x 72	78 x 80 x 99	5,000	12,000	55	2,000	1,200	12,700
GUS9612096	96 x 120 x 96	102 x 128 x 123	6,000	16,000	70	2,000	1,200	16,800

Additional sizes available

## ECO BURN OFF OVENS

- Designed with automated controls to minimize Cycle time
- Oven comes completely assembled and we provide thorough over the phone training on how to operate and maintain your ECO Burn-Off Oven
- End-to-end service solutions and expert over the phone assistance at no cost
- Replacement parts for all Ovens
- Safe, easily operated and ecologically sound



**Free Consultation-** We want to understand your company's needs, wants, and goals and show you how ECO Burn-Off Oven can help you achieve them.

**Technical Support-** We offer end-to-end service solutions and expert over the phone assistance at no cost.

**Assistance in Ordering Parts-** We offer replacement parts for all our ECO Burn-Off Ovens.

**Start-Up Operation and Maintenance-** Units come to you completely assembled and we provide thorough over the phone training on how to operate and maintain your ECO Burn-Off Oven.



[Request a quote for available sizes](#)



# EXAR<sup>®</sup> IS BUILT FOR THIS!

# EXAR<sup>®</sup> SFX-OR MOTOR LEAD CABLE

## 600V & 7500V IN STOCK AND READY FOR YOU!

SHOP NOW ON [EIS-INC.COM](https://eis-inc.com)



# CURING OVENS

## EIS# STEELMAN444GTC, STEELMAN666GTC, STEELMAN888GTC

- Insulated sides, top, & rear
- 14-16 gauge cold rolled steel exterior
- 16 gauge aluminized steel interior & airflow ducts
- Explosion relief door latches or hatches
- Lifting eyes and mounting brackets standard
- 99 hour digital timer with interlock on blowers
- Standard service 208,240, 460 & 480 volt (3 Ph / 60Hz)
- Air pressure proving switches for blower failure
- Gray enamel exterior finish on zinc rich primer
- Forced exhaust for removal of solvent vapor
- UL Listed control panel & components
- LED PID temperature control
- Air circulation & exhaust purge timer
- Door switch for heat and blower cutoff
- Back up high limit & deviation control
- Main line circuit breaker is included
- Cart not included



EIS #	INTERIOR DIMENSIONS			VOLUME INSIDE (FT <sup>3</sup> )
	WIDTH (IN)	DEPTH (IN)	HEIGHT (IN)	
STEELMAN444GTC	48	48	48	64
STEELMAN666GTC	72	72	72	216
STEELMAN888GTC	84	84	84	512

Additional sizes available

# SAHARA INDUSTRIAL CURING OVENS

### Standard Features

- Custom-built to your specifications
- Precise temperature control, including a thermo-couple actuated PID digital temperature controller and adjustable
- PID digital overtemperature protection
- Motor control push buttons
- On-off heat switch
- LED pilot lights
- 2-year Manufacturer's warranty

### Insulation

- 3" to 6" thick, 6# density mineral wool

### Heating Medium

- Electricity or gas
- Steam, hot oil, or hot water models available

### Temperature Range

- Room temperature to 500°F
- Ratings for 650°F or 800°F optional

### Options

- Exhaust vent with damper
- Interior door latch
- Outdoor use package
- Chart recorder
- Door switch
- Adjustable timer
- Ethernet or serial bus communication
- Profile temperature control with ramp and hold capability
- Industrially hardened SCADA (supervisory control and data acquisition) system capable of controlling 20 ovens
- Integrated PLC controls with touch screen
- Class "A" oven controls with powered exhaust systems, which are readily available upon request



Request a quote for available sizes.

# ELANTAS

## INSULATION YOU CAN COUNT ON!



Trickle Resins

SHOP NOW

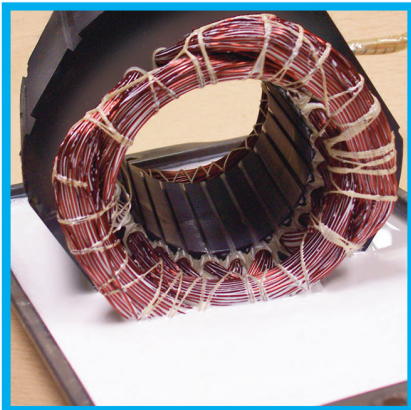
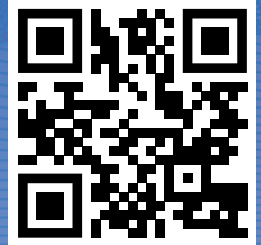

Dip and Bake Resins

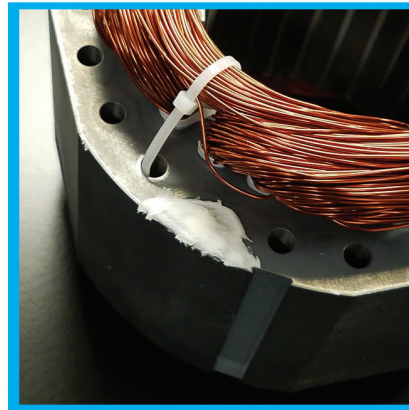

Masking Compounds



VPI Resins

**EASA**  
The Electro-Mechanical Authority  
MEMBER SINCE 1975





# BLAST-IT-ALL BLAST CABINETS

The LITTLE-BLASTER is constructed from heavy gauge metal, which is continuously welded. The LITTLE-BLASTER is also designed for a small company to start blasting with only a dust collector; then, without a lot of expense enables that user to convert to a reclamation system with the LITTLE-BLASTER Reclaimer Kit. While the LITTLE-BLASTER is limited to specifically smaller sizes than production type equipment, it is considered the highest caliber blaster manufactured today.

The Blast Cabinet 6048 Reclaimer and Dust Collector is constructed of 14 gauge reinforced metal. The working chamber features Double Walled Doors, Safety Door Interlocks, Self Adjusting Door Latches, Knife Edge, Self Sealing, Full Gaskets, and Full Length Hinges. This unit also has a large viewing window, interior lighting, a foot valve, media blasting gun, padded arm hold ports, and a blow-off gun.



## Additional options available

EIS #	DESCRIPTION
LB4824-300	LITTLE BLASTER SERIES 120V BLAST CABINET WITH 300 RECLAIM AND DUST BAG
6048-7 M2DC	6048 SUCTION SERIES 120V BLAST CABINET WITH 700 RELCAIM AND 700 M2DC

## Additional sizes and blast rooms available

# Streamline your shop with [EIS-inc.com!](https://www.eis-inc.com)

- View your orders
- Easily check shipment and tracking information
- Review and download invoices
- Quickly reorder products from previous orders
- Create shopping lists for efficient ordering
- Place orders online 24/7

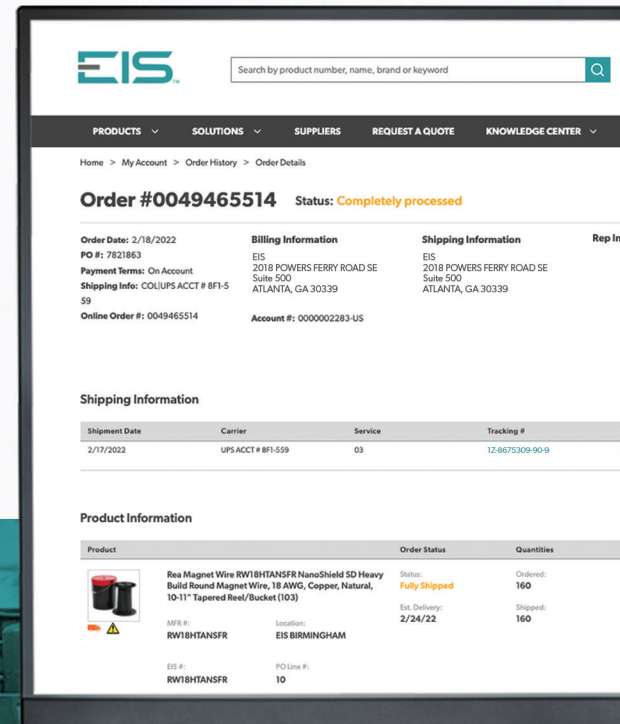

SHOP NOW



# PARTS WASHER

- Jam-proof roll-away door (top/center support)
  - Turntable wrap-around chain drive (jam-proof)
  - All welding certified (leak-checked 2x)
  - Lifetime guarantees
  - Ergonomic loading (height and toe-kick)
  - Industrial, high volume pumps
  - Isolation floor between spray chamber and tank
  - Slide-out chip/debris basket (stainless steel)
  - Sloped tank floor \*
  - Wash and heat timers, adjustable thermostat
  - Mid-swing cleaning manifold\*
- \*G-2000 & G-3000 Only

## Options Available

- Automatic Water Fill & Low Water Shutdown
  - Pump & Flow-thru Brush For Hand Detailing
  - Oil Skimming (must also order automatic waterfill & shutdown)
  - Automatic 7-day/24 hour Timer
  - Steam Exhaust Blower\*
  - In-Line Strainer\*
  - In-Line Micron Level Filter\*
  - ZXG Upper Turntable\*
  - Parts Trees for Hanging Small Parts\*
  - Small Parts Basket With Hinged Lids
  - Hydro-Air Rinse Gun
  - 230V / 460V 3-Phase Power
- \*G-2000 & G-3000 Only



Request a quote for available sizes

# VERTICAL CUT OFF SAWS

## Lancer L750 Vertical Cut Off Saw

- Dramatically reduce the time and effort you spend stripping motor coils with a Lancer Coil Cut Off Machine
- Will handle 48 frame thru 36" diameter motors on its table, and up to 48" diameter motors with the optional floor mount table
- Additional option is the powerlift which will automatically raise and lower the cutting arm



EIS #	DESCRIPTION
LANCERL750FMT	FLOOR MOUNTED TURNTABLE
LANCERL750PL	POWERLIFT
LANCERL750BASIC	NO MOTOR
LANCERL7503PH	3-PHASE MOTOR
LANCERL7501PH	1-PHASE MOTOR

# CARBIDE GRIT SAW BLADES

RemGrit® Carbide Grit Circular Saw Blades cut extremely hard abrasive materials. Cutting edge of tungsten carbide particles bonded to alloy steel back. High heat and abrasion resistance; no teeth to dull or chip; resists snagging; smooth cutting; greater wear resistance.

EIS #	DESCRIPTION
SAWGC302	3" COARSE GRIT
SAWGC408	4" COARSE GRIT
SAWGC652	6.5" COARSE GRIT
SAWGC703	7" COARSE GRIT
SAWGC805	8" COARSE GRIT
SAWGC507	10" COARSE GRIT



# MEDIUM DUTY COIL WINDERS

Pulling Power - High torque is delivered by the power train drive modules that supply torque on demand.

Coil Weight Capacity - Loads up to 1,000 Lbs. when used with ACE Model 65 Tailstock. Loads up to 500 Lbs. at FacePlate without tailstock.

Output Shaft - 1-3/8" Dia. shaft is tapped to accept 5/8"-11 Bolt.

Braking - Full motor torque hold braking at zero speed. Dynamic braking produces accurate positive stopping.

Models 3 - VAS & 3-VPAS - 3 HP, 230/460V, 60Hz

Models 3 - HVAS & 3-HVPAS - 5 HP, 230/460V, 60Hz



3-VAS with optional touchscreen Controller

EIS #	TYPE	DIRECT DRIVE		BACK GEARING		HP DRIVE
		RPM SPEED	LBS. FT. TORQUE	RPM SPEED	LBS. FT. TORQUE	
ACE3VPAS	I	0 - 408	44	0 - 43	420	3
ACE3VPAS	II	0 - 296	62	0 - 31	587	3
ACE3VPAS	III	0 - 259	98	0 - 27	741	3

# HEAVY DUTY COIL WINDERS

EIS# ACEHD-03, ACEHD-05, ACEHD-10, ACEHD-20

Automatic Stop - Bi-Directional single level preset counter counts from 1 to 999,999 turn counts

Speed Control - Speed can be controlled either by the foot pedal or a panel-mounted potentiometer on the front of the machine

Instant Reversing Feature - The Vector Drive Controller has programmed acceleration and deceleration rates. The time to go from forward to reverse is only .2 seconds

Pulling Power - High torque is delivered by the power train drive modules that supply torque on demand

Braking - Full motor torque hold braking at zero speed. Dynamic braking produces accurate positive stopping

An optional Touchscreen controller is available for optimum performance and ease of use. Item VSSH Brake Spring Set Holding Spring. Engages when power is lost to the winder



Model HD shown with optional Touchscreen Controller

MODEL	HP	SPEED	TORQUE	FACE PLATE W/ TAILSTOCK LOAD (LBS)
HD-3-1	3	0 - 39	363 CT	5,300
HD-5-1	5	0 - 28	844 CT	5,300
HD-10-1	10	0 - 28	1688 CT	8,000
HD-20-1	20	0 - 34	2779 CT	8,000

Additional models available

# WINDING MACHINES

- PC driven not a microprocessor
- Capability of having virtually unlimited memory for storage of coil data (over 50,000 jobs versus the competition's 500 job capacity)
- The WM 4100, 4500, and 5000IT are field proven
- Computerized coil winder for both AC and DC coils
- Uses direct drive servo motors for the wire guide and arbor distance
- Reduce labor costs



## WM4100

Coil lengths up to 41", Pull 20+ wires in hand



### Technical Data

- Motor power-nominal 3 KW
- Motor power max load 5 KW
- Torque nominal 200 NM (up to 130 RPM)
- Torque max load 350 NM (up to 130 RPM)
- Connection voltage 230 V, 50/60 Hz
- Connection power 7 KVA
- Winding speed 25-300 RPM infinitely variable

### Working Range

For IEC frame sizes - 56-315

### Coil Dimensions

- Coil Diameter: 2"-41.75"
- Coil Circumference: 6.3"-130"
- Layer Width: 15.75" max
- Coil Lengths: up to 41"

### Dimensions

84"L x 67"H x 47"W

### Weight

1600 lbs

## WM4500

Coil lengths up to 50", Pull 30+ wires in hand



### WM 4500-PC Technical Data

- Motor power-nominal 3.0 KW
- Motor power max. load 5.0 KW
- Torque nominal 350 NM (up to 75 RPM)
- Torque max. load 610 NM (up to 75 RPM)
- Connection voltage 400 V, N, PE, 50 Hz
- Connection power 7 KVA
- Winding speed 10-200 RPM infinitely variable

### Working Range

For IEC frame sizes - 56-355

### Coil Dimensions

- Coil Diameter: 2"-50"
- Coil Circumference: 6"-155.5"
- Layer Width: 15.75" max
- Coil Lengths: up to 50"

### Dimensions

84"L x 67"H x 47"W

### Weight

1800 lbs

## WM5100

Coil lengths up to 57", Pull 50+ wires in hand



### WM 5100 Technical Data

- Motor power-nominal 4.0 KW
- Motor power max load 7.0 KW
- Torque nominal 500 Nm (up to 65 RPM)
- Torque max load 1000 Nm (up to 65 RPM)
- Connection voltage 400 V, N, PE, 50 Hz
- Connection power 9 KVA
- Winding speed 5-100 RPM infinitely variable

### Working Range

For IEC frame sizes - 56-400

### Coil Dimensions

- Coil Diameter: 2"-57"
- Coil Circumference: 6.3"-177"
- Layer Width: 15.75" max
- Coil Lengths: up to 57"

### Dimensions

95"L x 91"H x 42"W

### Weight

2,200 lbs

# Nanoshield

## Corona Resistant Magnet Wire

A Product by Rea using Nano Technology

SHOP NOW



— Exceptional resistance to voltage stresses

— Substantial insulation protection against transient spikes

— Enhanced resistance to thermoplastic flow

— Enhanced dielectric strength

— Exceptional flexibility without embrittlement

— Excellent resistance to heat and solvent shock conditions

— ROHS & REACH Certified



Since 1933, we have remained committed to setting the standard for product quality and expertise in the wire manufacturing industry. With cutting-edge technology, innovation processes, and manufacturing facilities across North America, we are redefining the wire industry and delivering the best possible product and experience for our customers.

Shop online at [eis-inc.com](http://eis-inc.com).

# DC HEAD ACCESSORY

EIS# WMDC2

DC head - The most rugged, best designed, easiest to use adjustable coil head made for DC coil winding

- Includes: former, setup accessories, and storage block
- 2 larger sizes now available

Diamond, Concentric and Round Nose AC winding heads are also available

Diamond, Concentric and Round Nose AC winding heads are also available



# 3-PHASE GROUP WINDING HEADS

EIS# CROWN2103, CROWN2106

**Model 2103** - design for 3-phase motors from 1/4 - 75 H.P. Mounts easily on Crown coil winding drives or any turning device with 13 1/2" swing.

**Model 2106** - design for three phase motors from fractional HP to over 300 HP. Mounts easily on Crown coil winding drives or any turning device with an 18".



# S&W CONCENTRIC HEADS

EIS# S/W660, S/W675, S/W680

**SW660** - Wind Motors from 1/10 HP - 30 HP. Large Round Nosed Head. 35 lbs. 20 steps.

**SW675** - Wind Motors from 1/10 HP - 300 HP. Large Round Nosed Head. 52 lbs. 20 steps.

**SW680** - Wind Motors from 2 HP - 500 HP. Large Round Nosed Head. 80 lbs. 12 steps.



SW660

SW675

SW680

# CONCENTRIC WINDING HEADS

Eleven Sets of Heads #1 through #11 - **ADJUSTMENT NEEDED FOR LENGTH ONLY!**

The winding forms mount on our 19" (48.3 cm) or 25" (63.5 cm) holders with an instant coil release that moves one winding form 2" (50.8 mm) closer to the other, and are marked in inches for rapid adjustment.



EIS #	DESCRIPTION
LA-101	#1 4-STEP ROUND TOP (7/8" - 2 9/16")
LA-102	#2 4-STEP ROUND TOP (1 1/16" - 2 3/4")
LA-103	#3 5-STEP ROUND TOP (1 5/16" - 4")
LA-104	#4 4-STEP ROUND TOP (1 5/16" - 3 7/16")
LA-105	#5 5-STEP ROUND TOP (1 9/16" - 4 1/2")
LA-106	#6 5-STEP FLAT TOP (1 1/8" - 4 5/8")
LA-107	#7 5-STEP FLAT TOP (1 1/2" - 4 15/16")
LA-108	#8 5-STEP FLAT TOP (1 1/2" - 5 3/16")
LA-109	#9 4-STEP FLAT TOP (1 5/16" - 4 11/16")
LA-110	#10 4-STEP FLAT TOP (1 1/16" - 4")
LA-111	#11 4-STEP FLAT TOP (1 1/16" - 3 1/4")
LA-114	#14 7-STEP ROUND TOP (1 5/16" - 5 1/8")
LA-115	#15 8-STEP FLAT TOP (2 11/16" - 7 11/16") *AVAILABLE UNTIL INVENTORY DEPLETED*
LA-115-HR	#15 HIGH RIB 8-STEP FLAT TOP (2" - 7 11/16")
LA-100	SET OF #1 - #11 CONCENTRIC WINDING HEADS
LA-100-HR-19	SET OF #1 - #11 CONCENTRIC WINDING HEADS, STANDARD 19" LONG HOLDER & INSTANT COIL RELEASE
LA-100-HR-25	SET OF #1 - #11 CONCENTRIC WINDING HEADS, SPECIAL 25" LONG HOLDER & INSTANT COIL RELEASE

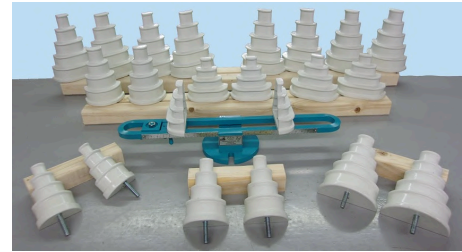

# LAYCOCK HOLDERS

- No sheet metal parts! - Machined from steel bar stock
- Eliminates the use of wrenches
- No stops to set
- Returns head to exact position every time!
- Fits 19" (48.3 cm) and 25" (63.5 cm) Laycock holders



EIS #	DESCRIPTION
LA-H-19	19" (48.3 CM) LAYCOCK HOLDER
LAYCOCKLAHR19	19" (48.3 CM) LAYCOCK HOLDER & INSTANT COIL RELEASE
LA-H-25	25" (63.5 CM) LAYCOCK HOLDER
LAYCOCKLAHR25	25" (63.5 CM) LAYCOCK HOLDER & INSTANT COIL RELEASE
LA-R	LAYCOCK INSTANT COIL RELEASE
LA-QR-4	LAYCOCK HOLDER, BLOCK ONLY (USABLE FOR BOTH 19" & 25")

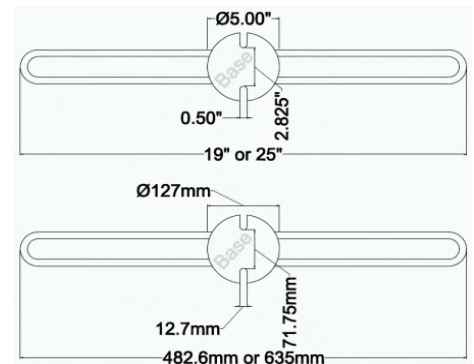

## S&W LAP CONTINUITY HEADS

Will wind three phase motors from 1/2 HP to 500 HP. Eliminate jumper connections saving 10% copper. Cut winding time by 40% and requires less tubing, tape and solder.



EIS #	DESCRIPTION
SW-500-00	LAP CONTINUITY HEAD 16 SLOTS - 1.5 IN. (38.1 MM) HEAD WIDTH - OAL 15.5 IN. (393.7 MM)
SW-500-0	LAP CONTINUITY HEAD 16 SLOTS - 2 IN. (50.8 MM) HEAD WIDTH - OAL 15.5 IN. (393.7 MM)
SW-501	LAP CONTINUITY HEAD 16 SLOTS - 2.25 IN. (63.5 MM) HEAD WIDTH - OAL 15.5 IN. (393.7 MM)
SW-502	LAP CONTINUITY HEAD 16 SLOTS - 3 IN. (76.2 MM) HEAD WIDTH - OAL 15.5 IN. (393.7 MM)
SW-503	LAP CONTINUITY HEAD 16 SLOTS - 3.5 IN. (88.9 MM) HEAD WIDTH - OAL 15.5 IN. (393.7 MM)
SW-504	LAP CONTINUITY HEAD 16 SLOTS - 4.0 IN. (101.6 MM) HEAD WIDTH - OAL 15.5 IN. (393.7 MM)
SW-505	LAP CONTINUITY HEAD 16 SLOTS - 5.0 IN. (127 MM) HEAD WIDTH - OAL 15.5 IN. (393.7 MM)
SW-506	LAP CONTINUITY HEAD 24 SLOTS - 6.5 IN. (165.1 MM) HEAD WIDTH - OAL 22 IN. (558.8 MM)
SW-507	LAP CONTINUITY HEAD 24 SLOTS - 8 IN. (203.2 MM) HEAD WIDTH - OAL 22 IN. (558.8 MM)
SW-508	LAP CONTINUITY HEAD 24 SLOTS - 9.75 IN. (247.7 MM) HEAD WIDTH - OAL 22 IN. (558.8 MM)
SW-550-1-5	(1-5) LAP CONTINUITY HEADS
SW-599	ALL 10 SIZES (00-8) LAP CONTINUITY HEADS ON A PALLET IN A BOX.

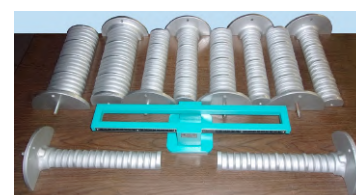

All of the above require S&W Holders for mounting (below)

## S&W HEAVY DUTY HOLDERS

- No sheet metal parts! - Machined from steel bar stock
- Eliminates the use of wrenches
- No stops to set
- Returns head to exact position every time!
- Fits 19" (48.3 cm) and 25" (63.5 cm) Laycock holders



EIS #	DESCRIPTION
S/W520Q	QUICK RELEASE FOR ALL S/W HOLDERS
S/W509H	LARGE HOLDER FOR ALL S/W HEADS 23.75" OVERALL LENGTH
S/W525Q	LARGE HOLDER AND QUICK RELEASE FOR ALL S/W HEADS.
SW-526-Q-1-5	LARGE HOLDER FOR ALL S/W HEADS 23.75" OVERALL LENGTH WITH HEADS 1-5 AND QUICK RELEASE.
S/W570H	EXTRA - LARGE HOLDER FOR ALL S/W HEADS 40" OVERALL LENGTH
SW-575-Q	EXTRA - LARGE HOLDER FOR ALL S/W HEADS AND QUICK RELEASE
S/W527Q-1-5	EXTRA - LARGE HOLDER FOR ALL S/W HEADS 40" OVERALL LENGTH WITH HEADS 1-5 AND QUICK RELEASE
SW-550-1-5	S&W 1-5 HEADS





# AEMC CLAMP-ON METER 512

## EIS# AEMC211768

- General purpose professional instrument that measures up to the toughest standards
- Rugged mechanical case and is designed using quality polycarbonate materials
- Compliance with international safety and quality standards
- Auto-ranging and provides the best measurement range and resolution for troubleshooting
- High resolution 40A range
- Measures AC current, AC and DC voltage, resistance, continuity with beeper, and frequency from V or A
- Features a diode test function

### Additional models available



# AEMC CLAMP-ON METER 607

## EIS# AEMC213961

- 1000V CAT IV Rated
- UL 94 flame retardant self-extinguishing
- IP54 Rated
- Measures up to 1000VAC (1400V peak), 1000VDC and AC+DC with resolution to 10mV
- Measures up to 2000AAC and 3000ADC
- Measures single- and three-phase power real, reactive and apparent) up to 3MW with resolution to 1W
- Measures frequency to 20kHz with 0.1Hz resolution
- Auto selects AC or DC measurement voltage
- Records up to 1000 measurements
- Wireless Bluetooth communications
- Jaw opening up to 2.36"
- Leads are constructed with a flexible silicone material

### Additional models available



# 10A 6240 & 6255 MICRO-OHMMETER

## EIS# AEMC6240

- Selectable test current and resistance ranges
- 0.1mΩ resolution
- Simple one button "press-to-start" operation
- Software temperature correction for accurate measurements
- Automatically takes multiple measurements by simply moving the test probes from point to point
- Stores test results internally
- Large easy-to-read backlit electroluminescent display
- Data storage, analysis and report generation through DataView® software included
- 6250 has manual/auto temperature compensation



# 10KV 6550 MEGOHMMETER

## EIS# AEMC6550

- Wide measurement range from 10kΩ to 30TΩ
- Fixed or programmable test voltage from 40V to 10kV
- 5 mA short circuit current
- Large backlit LCD screen with digital display, bargraph and R(t)+u(t), i(t) and i(u) graphs
- Automatic calculation of DAR / PI / DD / ΔR (ppm/V) ratios
- Multiple test modes: voltage ramp "burning", "early break" and "I-limit" modes
- 3 filters settings to optimize measurement stability
- Calculation of Resistance at a reference temperature
- Storage of 80,000 measurements and Real-time Clock
- Optically-isolated USB communication for transfer onto PC and report generation



# MA2-MOTORANALYZER R2

EIS# MDS-403168

Universal ALL-IN-ONE tester for electrical engineering, motor repair, maintenance and servicing.

- 15 different test methods
- Surge voltage up to 3000V with 0,45 joule
- High-voltage DC up to 6000V
- LCR measuring bridge
- Battery operation
- Automatic switchover
- Data is print capable with software
- Full motor diagnostics in a few minutes



**SCHLEICH** 

**MDS**  
MOTOR DIAGNOSTIC SYSTEMS

# DYNAMIC-MOTOR ANALYZER

EIS# MDS-403300

As a supplement to the MotorAnalyzer1, MotorAnalyzer2 R2 and the MTC2 winding testers, the Dynamic MotorAnalyzer completes your test device portfolio.

- Online monitoring for motors/generators during operation
- Measures voltage, current, power, harmonics...etc.
- Provides overall condition and performance data, including load, input power, and more
- For mains and VFD operation
- Unique multifunctional oscilloscope
- Unique Smart-FFT for broken rotor bar analysis
- Data recorder with real-time measuring values for subsequent analysis
- Trend analysis for preventive maintenance



**SCHLEICH** 

**MDS**  
MOTOR DIAGNOSTIC SYSTEMS

# MTC2 SERIES

EIS# MDS-MTC2-6KV-STD, MDS-MTC2-12KV-STD, MDS-MTC2-15KV-STD

The MTC2-Class instruments test windings in generators, three-phase stators, one-phase stators, transformers, armatures and motors. It provides Surge, DC Step Voltage and HiPot, PI, Resistance and Partial Discharge.

- Class leading equipment features
- Inspection of motors and generators up to 500 MW
- Surge voltage up to 50 kV
- Surge energy 125 Joule
- High surge current 2.000 A
- Fastest rise time 60 ns
- Fully-integrated partial discharge test according to IEC 61934 and DIN EN 60034-18-41



**SCHLEICH** 

**MDS**  
MOTOR DIAGNOSTIC SYSTEMS

NEW R7 SERIES

These units have PI Test Capability

# COMBINATION HIPOT/MEGOHMMETER

## EIS# PHENIXPM15-2

- Integral megohmmeter measures insulation resistance up to 1,000,000 MOhms @ 5 KV, 2,000,000 MOhms @ 10 KV, and 3,000,000 MOhms @ 15 KV
- Output voltage is continuously variable to 15 KVDC
- Illuminated push button guard mode selection bypasses stray or unwanted leakage current
- Zero start, safety interlock
- Adjustable overcurrent trip point
- Large easy-to-read analog meters
- Fully regulated output voltage
- Internal short circuit protection
- Integrated cable storage bin
- Light weight, rugged design
- Off zero and overcurrent trip buzzer



# PORTABLE DC HIPOT

## EIS# PHENIX475-20

- Lightweight and rugged for years of field use
- Models available with easy to read digital meters or
- A full-color touch screen display with data acquisition
- Internal discharge device
- Shielded high voltage output cable
- Guard measurement circuit



### Additional models available

AC INPUT		DC OUTPUT	
VOLTAGE	CURRENT	VOLTAGE	CURRENT
110 - 120 V	10 A	0-75 kV	20mA
220 - 240 V	5 A		

# CORE LOSS TESTERS

- Produces a hard copy printout
- Tests incoming and outgoing motors
- Price includes computer & printer
- Predicts a motor's reliability before and after repair
- Rotor clamps available for all models



EIS #	HP
PHENIXCL10B	500HP
PHENIXCL25B	1,250HP
PHENIXCL60B	2,500HP
PHENIXCL125B	5,000HP
PHENIXCL300B	12,000HP
PHENIXCL500B	20,000HP



# SMALL MOTOR TEST SET AC/DC

EIS# MTS100

The MTS100 is a combination AC/DC Motor Test Set specifically designed to provide economical testing capability for the smaller repair shop or for the small motor department of the larger shop.



## TEST CENTER

- AC/DC Motor test systems for fractional to 25,000 HP
- Continuously variable voltage at full power ratings
- State of the art operator interface and Windows software
- Robust column type voltage regulator with roller brushes for long life
- Optional physical measurement capability for temperature, vibration and RPM
- Standard 18 month warranty
- Test panels available from 500 - 2,500 KVA



## HIPOT INSULATION TESTERS

These HI-POT Insulation Testing units feature a built-in safety switch that immediately stops current flow in the event of a breakdown. In the event of a breakdown the indicator lamp will dim and a buzzer also signals a breakdown. Thus the operator can concentrate his attention on his work and not on the HI-POT tester. Power will not resume to the prods until the manual reset push button switch is activated.



HI-POT Insulation Tester Model 2119 features a built-in output voltage meter that displays the selector switch voltages.

EIS #	DESCRIPTION
CROWN2109	115V, 50-60 HERTZ, 7 POSITION VOLTAGE SELECTION WITH BUZZER, AUTOMATIC BREAKDOWN CIRCUIT, AND MANUAL RESET FEATURE
CROWN2119	115V, 50-60 HERTZ, 7 POSITION VOLTAGE SELECTION WITH BUZZER, AUTOMATIC BREAKDOWN CIRCUIT, AND MANUAL RESET FEATURE, ALSO FEATURES A VOLTAGE INDICATION METER
CROWN2129	230V, 50-60 HERTZ, 7 POSITION VOLTAGE SELECTION WITH BUZZER, AUTOMATIC BREAKDOWN CIRCUIT, AND MANUAL RESET FEATURE
CROWN2139	230V, 50-60 HERTZ, 7 POSITION VOLTAGE SELECTION WITH BUZZER, AUTOMATIC BREAKDOWN CIRCUIT, AND MANUAL RESET FEATURE, ALSO FEATURES A VOLTAGE INDICATION METER
CROWN2110	115V, 50-60 HERTZ, 7 POSITION VOLTAGE SELECTION, NO AUTOMATIC BREAKDOWN FEATURE
CROWN2120	115V, 50-60 HERTZ, 7 POSITION VOLTAGE SELECTION, NO AUTOMATIC BREAKDOWN FEATURE, INCLUDES A VOLTAGE INDICATION METER
CROWN2130	230V, 50-60 HERTZ, 7 POSITION VOLTAGE SELECTION, NO AUTOMATIC BREAKDOWN FEATURE
CROWN2140	230V, 50-60 HERTZ, 7 POSITION VOLTAGE SELECTION, NO AUTOMATIC BREAKDOWN FEATURE, INCLUDES A VOLTAGE INDICATION METER
2160	REPLACEMENT PROD AND LEAD ASSEMBLY SET FOR ALL UNITS



2109/2129



2110/2130

# COIL TAMPING PLIERS

## EIS# LA-TP

No more struggling with stator or armature windings that cannot be tamped with conventional tamping tools.



- Jaws are machined from steel bar stock instead of easily bent sheet metal
- Jaws are easily changed with screws
- No tool like this is on the market!
- Designed to tamp the windings in long bore or small bore stators where restricted space does not allow the use of conventional tamping tools and hammers.

A set consists of the coil tamping pliers (overall length 11") and 5 different jaws machined from steel bar stock. The jaws are easily changed to fit your special needs and may be purchased as a set or individually.

EIS #	DESCRIPTION
LA-TP-J-1-5	SET OF TAMPING PLIERS & FIVE JAW SIZES
LA-TP	TAMPING PLIERS
LA-TP-JAWS	SET OF JAW - FIVE SIZES
LA-TPJ-1	#1 JAWS - 5/32" WIDTH (4 MM)
LA-TPJ-2	#2 JAWS - 3/16" WIDTH (4.8 MM)
LA-TPJ-3	#3 JAWS - 1/4" WIDTH (6.4 MM)
LA-TPJ-4	#4 JAWS - 5/16" WIDTH (7.9 MM)
LA-TPJ-5	#5 JAWS - 3/8" WIDTH (9.5 MM)

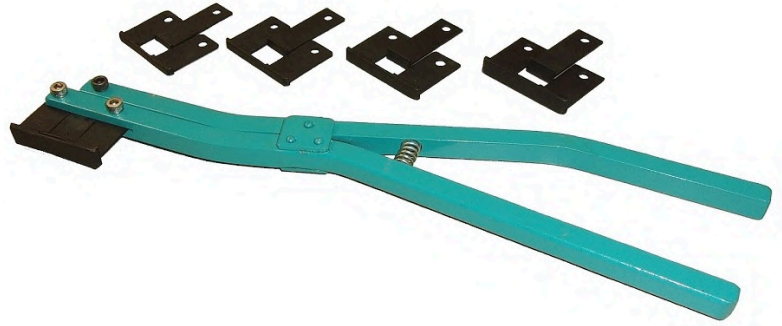

# WEDGE DRIVERS

- Prevents wedges from breaking or bulging while being driven into place
- Steel shell construction with a steel driver
- Shell length 6"



EIS #	DIMENSIONS
2211	1/32" X 3/8"
2212	1/16" X 3/8"
2213	3/32" X 5/8"
2214	1/8" X 5/8" (4 MM)
2215	3/16" X 5/8" (4.8 MM)
2216	1/16" X 5/8" (MM)
2217	1/8" X 7/8" (7.9 MM)

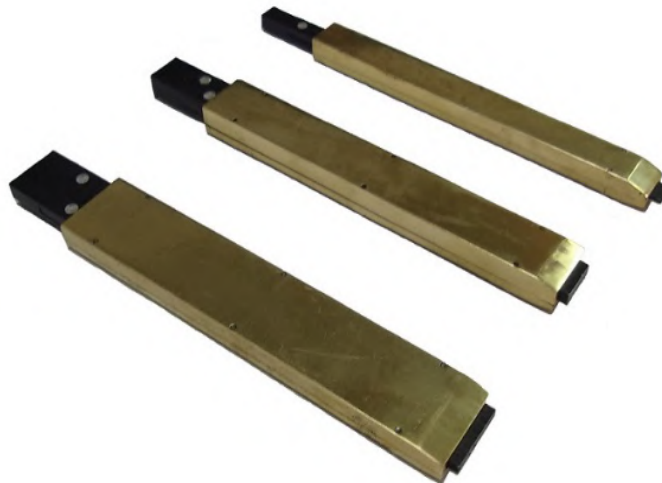

# STATIC MOTOR ANALYZER

EIS# BAKER99DX15RDSA3

In an industrial setting, the consequential cost of failure or unplanned downtime of critical rotating machinery can be significant. The Baker DX series can apply a wide set of off-line electrical tests to assess the condition of motors and coils.

- Comprehensive range of tests in one instrument
- Configurable to meet needs and price point
- 4 kV to 12 kV for wide spectrum of motors and coils
- Compatible with the Baker PPX Power Packs for testing up to 40 kV
- High and low voltage tests to characterize circuits and insulation
- Coil mode for rapid testing and data storage

Additional models available

**Megger**  
Baker Instruments



# ADX AUTOMATED STATIC MOTOR ANALYZER

EIS# BAKERADX-4-RLC, BAKERADX-12-RLC, BAKERADX12-RLC-PD, BAKERADX15ARLCPD

The ADX family includes models designed to perform tests at voltages up to 15 kV. The five main options include 4 kV, 6 kV, 12 kV, 15 kV, and 15 kV-A (Armature). Couple the ADX with a PPX to increase test voltages up to 40 kV for testing high voltage assets. Available ADX tests include:

- Winding resistance
- Inductance
- Capacitance
- Insulation resistance (IR)
- Dielectric absorption (DA)
- Polarization index (PI)
- DC HiPot (standard)
- DC HiPot (step-voltage)
- DC HiPot (continuous ramped)
- Surge analysis with EAR+™
- Partial discharge on surge

**Megger**  
Baker Instruments



FREE MTR105 TESTER  
WITH THE PURCHASE OF  
ADX 6KV OR HIGHER!

\*Promotion valid May 1 - June 30, 2024



# LOW RESISTANCE TESTER

EIS# MEGDLRO10HD, MEGDLRO10HDXDH4CP3

The DLRO10HD combines ultimate simplicity of operation with a rugged IP65 case designed for stable ground and bench operation. It is powered from either its rechargeable battery or line power, making it suitable for continuous testing in production line/repetitive use environments. Rotary switch controls are simple and easy to operate in all weather conditions and with gloved hands. A large, clear backlit LCD is easy to read from a distance. The DLRO10HD is capable of delivering 10 A into measurements up to 2500.0  $\mu\Omega$  and 1 A into measurements up to 25.000 m $\Omega$ . The duration of each test may be up to 60 seconds.

Also available is the DLRO10HDX which measures low resistance values in applications ranging from railways and aircraft to resistance of components in industry. Measurements on electric motors and generators will be inductive and require the user to understand the inductive mode and charging process before a correct result is achieved. The DLRO10HDX is well suited to measuring thick conductors, bonds and quality of welding because of its 10 A range for resistance values up to 250 m $\Omega$ .

Motors and Generators

- Coil resistance – using inductive mode
- Coil and turn-to-turn shorts
- Bar-to-bar tests
- Coil balance – cold to full load current comparison

**Megger**  
Baker Instruments



# ROTATING MACHINE TESTER

## EIS# MTR105

The MTR105 is a dedicated Static Motor Tester with Megger's tried and trusted suite of insulation resistance tests (IR), plus all the great traditional features and reliability of Megger's testers.

- Full color graphic display
- 3 Phase insulation resistance
- Temperature correction for insulation resistance
- Guard terminal
- DLRO four wire Kelvin
- Continuity and diode test
- Motor direction of rotation
- Capacitance and inductance
- CAT III 600 V up to 3000 m
- Environmental protection to IP54

**Megger**



# INSULATION TESTERS

## EIS# MIT400/2

The MIT400-2 series insulation and continuity testers are designed not just for Electrical and Industrial, but with an exceptionally wide range of applications from electrical installations, cable testing, motor testing, automotive, ESD, panel building, avionics, maintenance etc.

- Insulation testing up to 1000 V and 200 G $\Omega$  range
- Stabilised insulation test voltage (New)
- Single range, faster continuity testing from 0.01  $\Omega$  to 1 M $\Omega$  (New)
- 600 V Trms AC and DC voltage measurement
- Live circuit detection and protection
- User variable insulation test voltage from 100V to 1000V (New) depending on model
- Test result storage and Bluetooth® downloading depending on model
- Rechargeable options for mains and car charging (New) depending on model
- CAT IV 600 V & IP54

**Megger**



### Additional models available

# ADVANCED WINDING ANALYZER IV

## EIS# BAKERAWAIV-2.2KV, BAKERAWAIV-4KV, BAKERAWAIV-6KV, BAKERAWAIV-12KV

Range includes 2 kV, 4 kV, 6 kV and 12 kV models.

- Testing capabilities include: surge, winding resistance, Megohm, PI, DA, continuous ramp DC step-voltage, and DC hipot tests
- 12 kV HO (high-output) version for performing surge tests on large motors and generators
- Compatible with Baker PPX Power Packs to extend insulation testing voltage range (6 kV, 12 kV and 12 kV HO versions only)
- IEEE- and IEC-compliant surge test
- Surge waveform comparison by the patented Pulse to Pulse Error Area Ratio (PP-EAR) technique
- Incorporates advanced inter-turn assessment capabilities in a field portable instrument
- Microsoft Windows 10 Embedded operating system
- USB port for data transfer and printing with Windows 10 plug-and-play printers

**Megger**

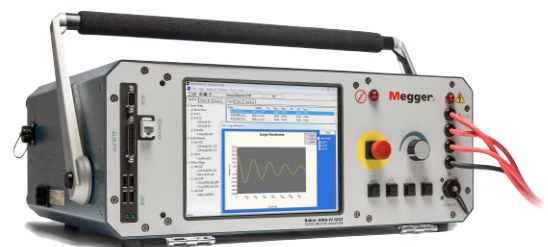

Buy from our participating strategic suppliers to earn  
EIS Rewards program multipliers on your purchases!

**EIS**  
REWARDS



## WELDING, BRAZING, & SOLDERING GAS GENERATORS

EIS# OWELDM10000, OWELDM20000, OWELDM30000

- Instant 6,600° F flame
- Uses distilled water as a fuel source
- Adapts to all metals
- Service led: when it is service time the machine gives you a warning
- Automatic condensation discharge with electrovalve
- Software and electronics constantly checking the activity and performance of the unit:
  1. Performance checks
  2. Four different water levels
  3. Working hours
  4. Work load
- All components are more robust
- Cooling system: large stainless steel heat exchanger
- Cooling EBM fan



OWELDM20000  
OWELDM30000



OWELDM10000

EIS #	DESCRIPTION
OWELDM10000	10,000 max watts
OWELDM20000	20,000 max watts
OWELDM30000	30,000 max watts



No more gas  
cylinders for brazing!



# EMQ-INSULATED SLEEVES

Repair bearing housings-quickly & economically



## PROBLEM

Bearing damaged by electrical corrosion - current passing through the bearing causes fluting and pitting

## SOLUTION

INSULATED SLEEVES - Thermoplastic Polymer Alloy Advantages:

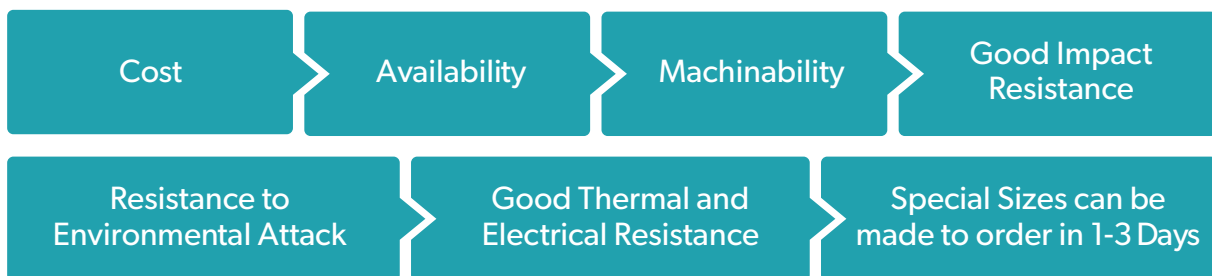

## PRODUCT OFFERING

### SA E 1026 Steel

- Available from stock in sizes up to 6240 and 6332 ball bearing (.150" wall thickness on standard sleeves)
- .100" wall thickness available on thin walls
- These are recommended for bearing housings with utile room for machining
- All sleeves machined to  $\pm .0002$ "

### Class 35-40 Grey Iron

- Available from stock in sizes up to 6232 and 6330 ball bearing
- .100" - .080" wall thickness available on thin walls
- All sleeves machined to  $\pm .0002$ "



SHOP NOW

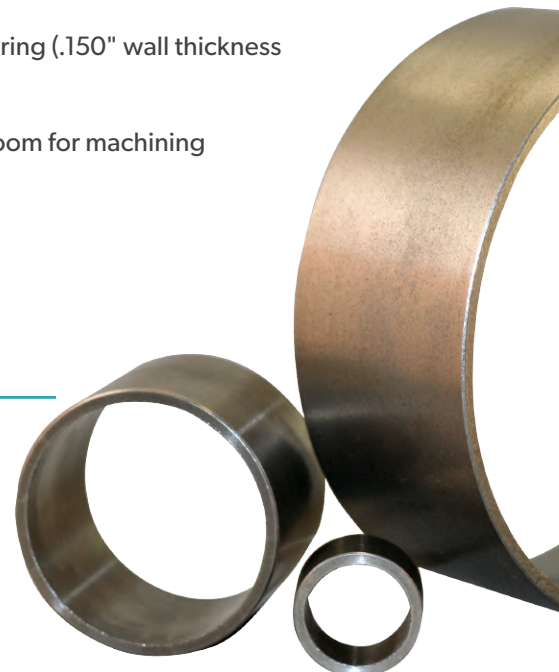

# HYDRAULIC PULLER

## EIS# PH-50T



The PH-50T puller set includes the necessary components to tackle those large pulling jobs. The hydraulic lift cart makes moving, storing and using the 50-ton puller easy and convenient. The hydraulic lift easily raises the puller from 19 in. (482 mm) to a height of 44 in. (1117 mm). The mounting platform allows the puller to swivel a full 360 degrees. This set includes both standard and long jaws to tackle any pulling job.

- Patented Safety Cage design holds the pulling jaws securely in place preventing the jaws from snapping back or slipping off the work surface
- Remote Jog Switch on electric pump with 10-foot cord (3.05m)
- Convenient Storage for jaws
- Floor Lock securely stabilizes cart
- Large Wheels allow easy movement of cart to place puller into position
- Ram point Storage
- Front Swivel Castors locking feature for ease of mobility
- Lifting Eyes permit use of an overhead crane to raise entire assembly
- Pin locks puller in place allowing puller to be used 90 degrees to right or left of centerline
- Patented Safety Cage design holds the pulling jaws securely in place preventing the jaws from snapping back or slipping off the work surface



EIS #	CAPACITY TONS (KN)	NUMBER OF JAWS	REACH IN. (MM)	SPREAD IN. (MM)	REACH IN. (MM)	SPREAD IN. (MM)
PH-50T	50 tons (445 kN)	3	14 in. (356 mm)	3 to 25 in. (76 to 635 mm)	26 in. (660 mm)	2 to 38 in. (51 to 965 mm)

### Additional models available

# PULLEY PULLERS

- Designed specifically to be used in motor repair shops
- Hydraulic pulley puller is available in four capacities ranging from 8 tons to 100 tons
- The IPP portable hydraulic puller is designed to be utilized by one person
- Known for high quality, durability, and ease of use

## Industrial Pulley Puller

EIS #	CAPACITY (TONS)	HYDRAULIC PUMP	DESCRIPTION
IPP8TON	8	Manual	Wheel Mount
IPP20HTON	20	Manual	Wheel Mount
IPP20ETON	20	Electric	Wheel Mount
IPP60HTON	60	Manual	Wheel Mount
IPP60ETON	60	Electric	Wheel Mount
IPP100ETON	100	Electric	Wheel Mount
IPP100ETON-LPE	100	Electric	Low Profile



IPP8TON



IPP60ETON



IPP100ETON

### Also available:

- Low profile
- All welded four side fork truck platform

# 3NC HYBRID-CERAMIC BALL BEARINGS

# JTEKT

Ball, Needle & Roller Bearings

Formerly sold as

**Koyo.**



SCAN ME

## Suited For a Wide Range of Extreme Applications

**Compared to steel balls, ceramic balls are lighter, smoother, harder, and resistant to both corrosion and electrical currents**

**Lower operating temperatures (up to as much as 40%) resulting in longer grease life.**

**Lower rotational torque than steel ball bearings which means less energy is required to rotate the bearing.**

**Eliminates electric arcing or fluting by insulating the bearing from stray currents.**

**Reduces down time and maintenance resulting from traditional steel ball bearing failure.**

**Dimensionally interchangeable with current electric motor bearing.**

**No additional machining required.**

**No special modifications or handling required for installation.**



# FOOT SQUARING SHEARS

FOOT-SQUARING SHEARS	MODEL 36	MODEL 52
MAXIMUM SHEARING CAPACITY, MILD STEEL	16 GAUGE/1.6 MM	16 GAUGE/1.6 MM
MAXIMUM SHEARING CAPACITY, STAINLESS STEEL	20 GAUGE/1.0 MM	20 GAUGE/1.0 MM
MAXIMUM CUTTING LENGTH	37 IN./940 MM	52-1/4 IN./1327 MM
BACK GAUGE RANGE	30 IN./762 MM	30 IN./762 MM
FRONT GAUGE RANGE	37 IN./940 MM	37 IN./940 MM
FLOOR SPACE, GAUGES IN POSITION	45 X 80 IN. 1143 X 2032 MM	60 X 80 IN. 1524 X 2032 MM
DIMENSIONS, LESS GAUGES, LXWXH	46-1/2 X 27 X 42 IN. 1181 X 686 X 1067 MM	61 X 36 X 42 IN. 1550 X 915 X 1067 MM



EIS #	DESCRIPTION
CROWNTENN36	FOOT SQUARING SHEAR MODEL 36
CROWNTENN36A	AIR POWERED SQUARING SHEAR MODEL 36A
CROWNTENN52	FOOT SQUARING SHEAR MODEL 52
CROWNTENN52A	AIR POWERED SQUARING SHEAR MODEL 52A
CROWNTENN52H	HYDRAULIC SQUARING SHEAR 440V, 52H

# INSULATION FORMER

EIS# 2301, CROWN2301

## 2301

The 2301 insulation former will form slot insulation quickly and neatly, plain or cuffed, up to 8" wide with any length. It insures uniform slot liners; speeding winding and preventing burnout's due to improperly fitting or torn slot lining.

## 2301M

The "Motorized Crown Insulation Former" permits forming insulation at the rate of 100 feet per min. it is designed for plain or cuffed insulation, also forms slot insulation up to 8" wide any length. It does the job faster, easier, and forms neater fitting and more uniform slot lining that can be formed by hand.



2301M

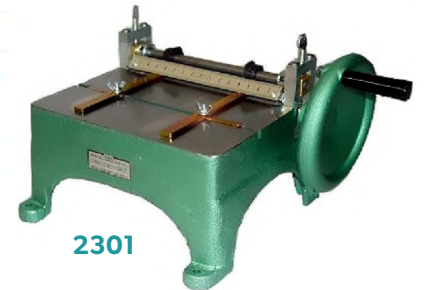

2301

# CREASER / CUTTER

EIS# LENLCC14, LENLCC9

This unit lets you turn cuffed coils into accurately formed slot liners quickly and easily. This cutter has been the motor rebuilding industry standard for 60 years.

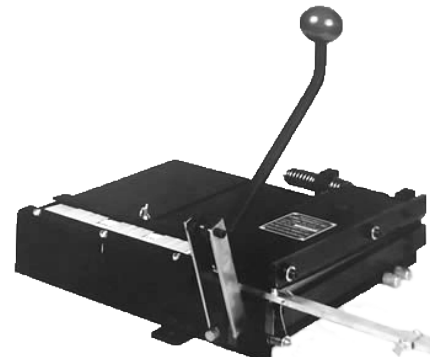

# KUTRIMMER

EIS# KUT1080, KUT1110A

- Solingen steel blade set may be resharpened
- Special wide-angle blade cuts heavy materials such as matteboard, plastic, and metal foils
- Transparent Lexan® safety guard and blade lock
- Foot pedal for positive clamping
- Precision side guides scaled in inches and metric system
- Lockable back gauge, front gauge is adjustable using a calibrated rotary knob with fine adjustment scale, lockable in every position
- Narrow strip cutting device
- Fold-down extension table provides support for large cutting jobs
- Standard paper sizes indicated on table
- All metal construction

**MBM** **KUTRIMMER®**  
by IDEAL



31" CUT LENGTH



43" CUT LENGTH

# TABLE SHEAR WITH WORK TABLE AND GUARDS

EIS# RLM-SHEAR-110, RLM-SHEAR-160

- Manual cutting table for blocking cardboard, paper, vinyl, cellophane, leather, rubber, etc.
- Strong steel & cast iron structure can be disassembled
- Adjustable blade alignment with movable bearings
- Spring loaded back gauge adjustable by hand wheel
- Hold down bar which foot pedal action
- Steel work table & strip collector tray
- Right angle table gauge which ruler
- Hardened Steel Blade with 59 Rockwell
- Available table widths of 43" & 63"
- Made in Italy



# PATRIOT® 12-TON C-HEAD BATTERY CRIMPER, HYDRAULIC SELF-CONTAINED

EIS# BURPAT750T3U03A2

PAT750 12T C-Head Battery Crimper, 3Ah Li-ion, AC, Hard Case.

- C-Head with 1.65" jaw opening
- 355° head rotation
- Uses U dies
- Ergonomic design and overmolded handle for comfort grip
- Patented T-Track alignment guide for HYGROUNDR® as well as other asymmetrical connectors
- Accepts 2.0Ah-6.0Ah Makita Lithium-ion Batteries



 **BURNDY**

Additional models available

# ABISOFIX WIRE STRIPPER

EIS# WMABISTRANS\*, WMABISSTRIPPER\*

\*Both parts are needed for unit to work correctly

- Hand held rotary blade enamel stripper
- All purpose tool capable of removing the enamel insulation from copper wire to facilitate termination, e.g., soldering wire ends of stator and transformer coils
- The abisofix stripping head utilizes three weighted tungsten carbide blades, the depth of strip being controlled by a low voltage bench power supply/speed control unit





# ISO-LEX WIRE STRIPPER

EIS# WMISOL2, WMISOL3

- Strips enamelled insulation from round copper conductor with built-in speed control, runs direct from the outlet without transformer
- WMISOL3 - Wire range 16 - 32 gauge
- WMISOL2 - Wire range 12 - 22 gauge







# ABISOBRUSH WIRE STRIPPER

EIS# HQ35P / HQ35P-SA

- Hand held stripping device for wires (1.5 - 6mm diameter) and flat copper (1 - 6mm thickness)
- 230 V (115 V) 50 Hz
- Weight 2.4kg, Brush size 35mm





# MEGAOHM CERAMIC INSULATED BEARINGS COMBAT ELECTRICAL ARCHING LIKE NO OTHER

- Ceramic coated for electrical insulation that prevents electrical pitting & fluting
- Drop-in replacement for standard bearings
- Cost effective solution to combat stray electrical currents



## SELF CENTERING MECHANICAL PULLERS

EIS# **MECHPULLER23120, MECHPULLER23180, MECHPULLER23270**

- Convertible between 2 and 3 arms
- Made from hardened steel
- Self-centering mechanism aligns arms, self locking arm prevents bending and slipping

EIS #	CAPACITY TONS	MAX SPREAD (IN)	MAX REACH (IN)
MECHPULLER23120	2	4.7	3.1
MECHPULLER23180	3	7.1	4.7
MECHPULLER23270	5	10.6	6.3



## SELF CENTERING HYDRAULIC PULLERS

EIS# **SCHYDPULLER-4T, SCHYDPULLER-12T, SCHYDPULLER-20T**

- A range of powerful pullers for a safe and easy dismounting of large bearings and force-fitted parts such as pulleys and gear wheels
- The self-centering device facilitates positioning and anchoring around the bearing. The power developed by the hydraulic system allows the part to be extracted safely with very little effort

EIS #	CAPACITY TONS	MAX SPREAD (IN)	MAX REACH (IN)
SCHYDPULLER-4T	4	12.83	7.5
SCHYDPULLER-12T	12	19.09	12
SCHYDPULLER-20T	20	22.44	14.4



# HEATER-SMART

SCHAEFFLER

## TEMPERATURE MODE

For controlled heating to the desired temperature.

## TIME MODE

For serial heating without temperature sensors, when the necessary heating time is known.

## TIME OR TEMPERATURE MODE

For controlled heating to the desired temperature or duration.

## TEMPERATURE AND SPEED MODE

For controlled heating with the maximum temperature gradient per unit of time.

Additional sizes available



# MF INDUCTOR

SCHAEFFLER

- Handy and easy to use
- Lightweight handheld without temperature control
- Usage with flexible or fixed inductors
- Various performance variants available
- Can be operated with one hand
- Ideal for small work pieces
- Low-cost tool for workshops



# ALIGNMENT SYSTEMS

SCHAEFFLER

Belt alignment devices, belt tension meters and shaft alignment devices



# HYDRAULIC TOOLS

SCHAEFFLER

For hydraulic mounting and/or dismounting of bearings with a tapered bore



# MECHANICAL TOOLS

SCHAEFFLER

For mechanical or hydraulic dismounting of bearings





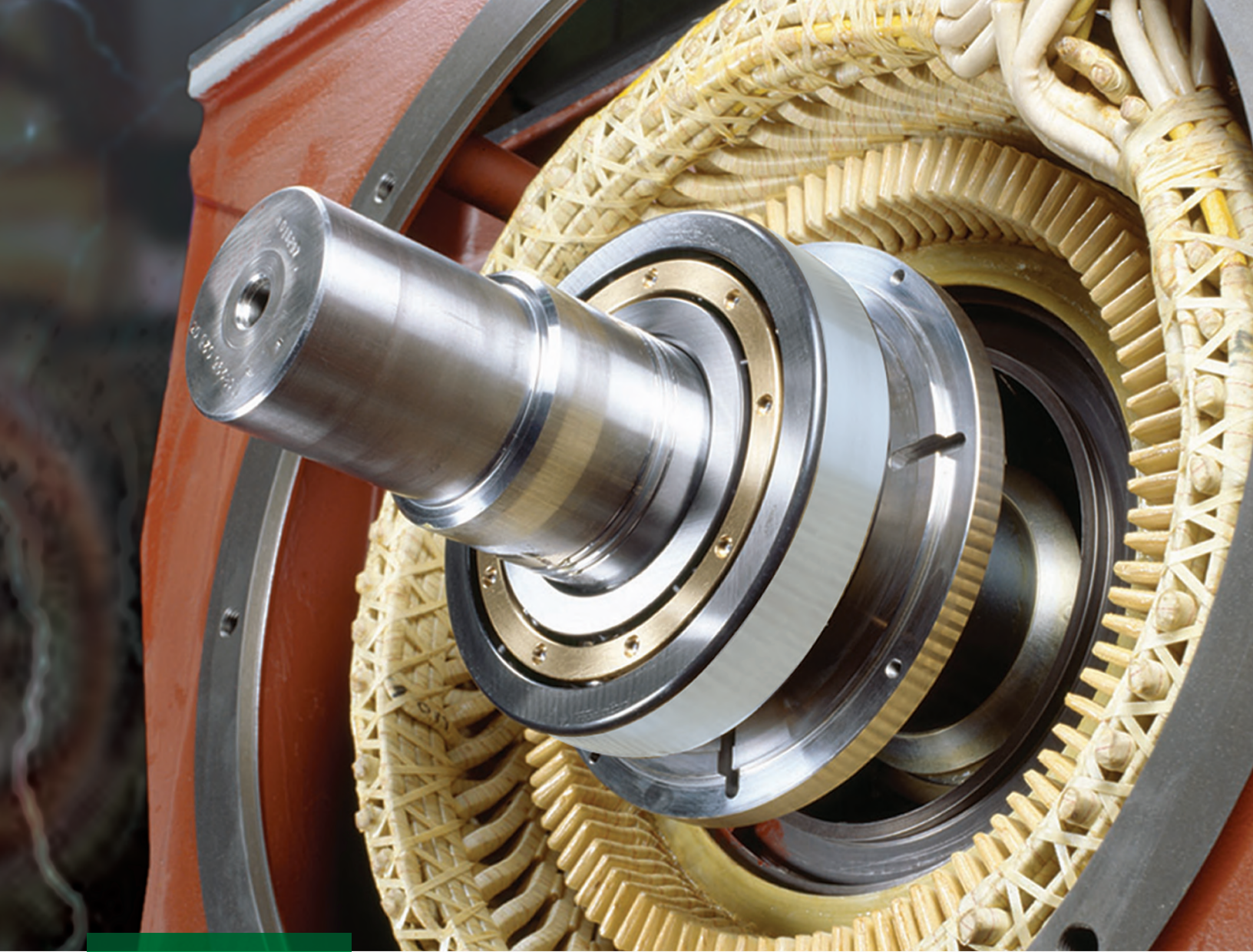

We pioneer motion

## Stray Electric Current: Meet Your Match

**The problem:** Damage caused by electrical current passing through bearings in electric motors.

**The solution:** Current-insulated bearings from Schaeffler — including hybrid ceramic or ceramic-coated versions featuring our proprietary Insutect™ coating — that have been engineered to stop stray electric current in its tracks.

Now that's electrifying!

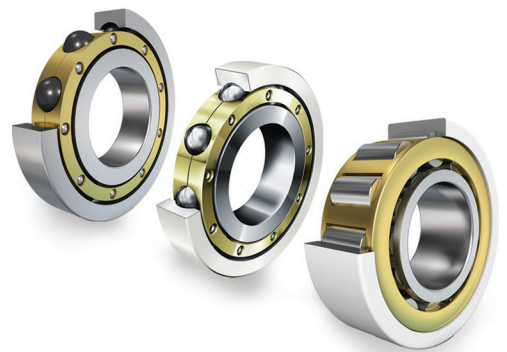

**FAG**

**EIS**<sup>™</sup>

**SCHAEFFLER**

## DEEP GROOVE BALL BEARINGS

- Longest Life Designs
- Selected Material
- Optimally Controlled
- Low Torque & Low Noise
- Higher Performance & Reliability



**NACHI**



SHOP NOW

### “NSE” NITRILE SEAL

- U-shaped seal groove
- Triple acting seal lips
- Low torque & low noise
- Superb grease retention
- High performance grease w/torque



### “ZE” METALLIC

- L-shaped shield
- Low torque
- Quiet operation
- High performance grease
- Superior grease retention

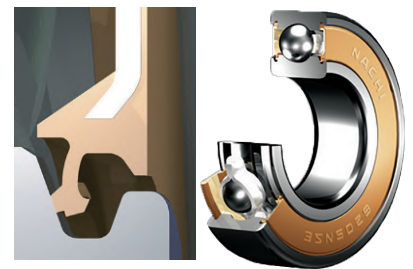

## FLUSH GROUND ANGULAR CONTACT BALL BEARINGS



- Machined Brass Cage
- ABEC 1 Tolerance
- 40 Degree Contact Angle
- Flush Ground Type (U)

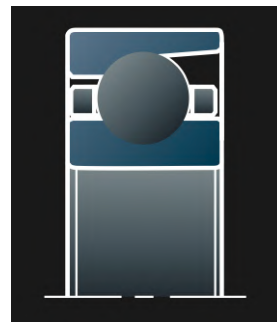

- Flush ground for versatility
- Ease of assembly and simplified inventory control
- Mountable as DB, DF and DT pairs
- Can be combined to form triplex or quad sets

**NACHI**

## PORTABLE INDUCTION HEATER

EIS# TWIM15-110V, TWIM15-230V

**SKF**®

The SKF portable induction heater TWIM 15 is designed to heat up roller bearings that are mounted with an interference fit onto a shaft. Heating the bearing causes it to expand, which eliminates the need to use force during installation. Generally, using the TWIM 15 to generate a 90 °C (162°F) temperature difference between the bearing and shaft is sufficient to enable installation. In addition, the TWIM 15 can be used to heat other ring shaped, metallic components, providing flexibility of use.



EIS #	MAX POWER	VOLTAGE	FREQUENCY	MAX CURRENT
TWIM15-120V	1,8 kVA	110 V	50/60 Hz	16A
TWIM15-230V	2,3 kVA	230V	50/60 Hz	10 A

## SMALL INDUCTION HEATER

EIS# TIH030M/110V

**SKF**®

- Compact lightweight design; 46.0 lb facilitating portability
- Two-step power setting and smaller yokes allow heating smaller bearings safely and at lower power consumption
- Capable of heating a 62 lb bearing in just 20 minutes
- Supplied with three yokes; allowing bearings with a bore diameter from .8 inches up to a maximum weight of 90 lbs to be heated
- Temperature mode preset at 230 °F to help prevent bearing over-heating
- Automatic demagnetization

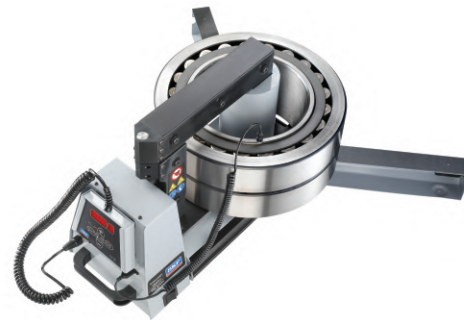

## MEDIUM INDUCTION HEATER

EIS# TIH100M/230V

**SKF**®

- Standard swivel arm for large-size yoke
- Capable of heating a 210 lb bearing in less than 20 minutes, saving time and energy
- Two-step power setting and smaller yokes allow heating smaller bearings safely and at lower power consumption
- Supplied with three yokes; allowing bearings with a bore diameter from .8 inches up to a maximum weight of 264 lbs to be heated
- Temperature mode pre-set at 230 °F to help prevent bearing over-heating
- Automatic demagnetization
- Available in two executions: 230V/50-60Hz or 400-460V/50-60Hz



## ALIGNMENT TOOLS

EIS# TKSA-5104, TKSA4104, TKSA3104, TKSA6004, TKSA71-WPODS04

**SKF**®

Misalignment of shafts, belt drives and chain drives is a major contributor to rotating machinery breakdowns. Accurate alignment can prevent a large number of machinery breakdowns and reduce the number of unplanned stops and loss of production. Accurate alignment can also help to extend the life time of your machines.

SKF offers the following alignment tools:

- Belt alignment tools
- Shaft alignment tools
- Adjustable chocks
- Machinery shims

7 MODELS AVAILABLE!



## DYNAMIC BALANCER

- Self-aligning
- Comes completely equipped
- Automatically compensates for uneven floors
- Accommodates longer than normal rotors
- Dynamic balancers for rotors, fans, pulleys, gears, and other rotating parts
- Mounting system is 35% more sensitive than competitive machines

EIS #	MAX WEIGHT (LBS)
DYNABALD15	1500
DYNABALD25	2500
DYNABALD40	4000
DYNABALD60	6000

Additional models available



## HORIZONTAL HARD-BEARING BALANCER

The Hofmann horizontal, hard-bearing balancing machines H-13 through H-34 are used for high-precision balancing of various small to very large rotors with a max. weight up to 220,000 lbs.

Balancing of rotors from:

- Electric motors and generators
- Fans
- Turbines and compressors
- Large turbocharger

Additional sizes available



## OPEN FACED SPRAY BOOTH

- 18 Gauge Galvanized Steel
- Booths below come with all necessary accessories for installation
- Not Customizable - VOF's come standard "as is"
- ETL Listed
- Control Panel, Air Solenoid Valve, Bulbs and Crating
- Exhaust duct for 15' roof (does not include flashing - Please order appropriate flashing part number below in the roof flange section)

### Upgrades / Options

- (1) 4-Tube, 5000K, T-8 Fluorescent Light Fixture to 6000K, L.E.D. tubes
- 24" Flashing
- 30" Flashing
- 42" Flashing



WIDTH (FT)	DEPTH (FT)	HEIGHT (FT)	OVERALL DEPTH (FT)	LIGHT FIXTURE	FAN & MOTOR SIZE	NUMBER OF FILTERS	CFM AT 0.625"
6	5	8	7.33	(1) 4 TUBE LIGHT FIXTURE	24" FAN/2 HP MOTOR	12	5800
8	7	8	9.33	(1) 4 TUBE LIGHT FIXTURE	24" FAN/2 HP MOTOR	16	7650
10	7	8	9.33	(2) 4 TUBE LIGHT FIXTURE	24" FAN/2 HP MOTOR	20	7650
10	10	10	12.33	(4) 4 TUBE LIGHT FIXTURE	24" FAN/3 HP MOTOR	25	10100
12	7	8	9.33	(2) 4 TUBE LIGHT FIXTURE	24" FAN/3 HP MOTOR	24	10100

Larger sizes available

# BENCH-TYPE UNDERCUTTER MODEL HV-3

EIS# HV3UA1, HV3UA3, HV3UB1, HV3UB3

- Longer armatures on V-supports, which can be spread to 23" between inside edges, and have 1" vertical adjustment
- Takes armatures 10-1/2" diam. on centers or 12" on V-supports
- Handles commutators: Vertical - 5-1/4" diam.; Horizontal - 6-1/2" diam. x 6-1/2" long
- Saw lifts out of slot on return stroke
- Specifications: 20"
- 20" between centers



EIS #	VOLTS	HERTZ	SPINDLE (IN)
HV3UA1	115	50/60	1/8
HV3UA3	115	50/60	3/16
HV3UB1	230	50/60	1/8
HV3UB3	230	50/60	3/16

## HEAVY DUTY BENCH-TYPE UNDERCUTTER

EIS# MARTINH-9UA5

- Model H-9 uses either high-speed steel or carbide saws and V cutters
- Handles armatures from the small sizes up to 17" diameter
- Spindle speed easily changed for high-speed steel or carbide saws
- Cutting head carriage travels freely on ball-bushings
- Adjustment provided for aligning to skewed commutator bars
- 115 V., 50/60 Hz. with 5/16" spindle



Other sizes available

## LATHE-TYPE UNDERCUTTER

EIS# MARTINLTHU101A

- Can be quickly attached in place of the tool post on any lathe
- Can be mounted directly on the cross slide or on the slide carriage which is then mounted on cross side
- 1/3 HP motor using high-speed steel or carbide saws or V cutters
- 115 V., 50/60 Hz. with 3/16" spindle



Other sizes available

## AIR DRIVEN MICA MILLER

EIS# MARTINM-MU202

- Popular, lightweight, rugged, and a powerful tool
- Available in two models for use with high-speed steel or tungsten-carbide saw blades
- 5,800 RPM model, for use with solid carbide saw blades, is great for prolonged use on larger commutators
- Less stopping to change blades saves you time and money



## BRUSH SEATERS

- Brush Seating and Cleaning Stones
- Brush Seater Holders
- Brush Seaters with Handles



# EDDY CURRENT ECB-SERIES DYNAMOMETER

- These electric motor dynos allow for ease of testing as they offer the advantage of dissipating heat via air-cooled fin technology.
- They allow for minimal HP testing without the need for water to cool.
- PC Control: DC drive control via real-time data acquisition PC
- Closed loop control: real-time PID set-point control (RPM/torque)
- Hand-held control: wireless hand-held control with data acquisition readouts
- Manual control: manual hand-held potentiometer



EIS #	MAX RPM	WEIGHTED LIFTING CAPACITY	POWER (HOT RATINGS)	
			1800 RPM	3600 RPM
AWDECB10	10000	100	.25-5HP (.2-3.75KW)	.5-10HP (.37-7.5KW)
AWDECB50	5000	500	3-37HP (2.25-28KW)	8-50HP (6-38KW)
AWDECB100	5000	1000	6-85HP (4.5-64KW)	9-100HP (6.75-75KW)
AWDECB200	5000	2000	8-160HP (6-120KW)	15-200HP (11-150KW)
AWDECB400	5000	4000	16-320HP (12-240KW)	30-400HP (22-30KW)

# E-SERIES DYNAMOMETER

- These electric motor dynos have the ideal control response! As torque is not dependent upon water-flow in these electric motor dynos. The electric motor dynamometers of these series allow for precise set-point control due to lock of control flow oscillation.
- Electric Motor Dynamometers base serves as a ballast weight for high-torque applications. Dyno unit necessitates prescribed amount of supply water (GPM) per 100 HP.
- Safety fuse (releases at 185° F) allows for power absorption unit protection through automatic disengagement of hydraulic pressure within hydraulic control system of the electric motor dynos.
- Engine dynos are fully operable upon receipt. An AW representative completes your dynamometer purchase through on-site training of key personnel on the functionality and maintenance of the dynamometer unit.



EIS #	RATINGS	HP(Kw) @ 3600 RPM
AWDI300E	300 HP AT 3600 RPM / 200 HP AT 1000 RPM	300 (225)
AWDI600E	600 HP AT 3600 RPM / 400 HP AT 1000 RPM	600 (450)
AWDI900E	900 HP AT 3600 RPM / 600 HP AT 1000 RPM	900 (675)
AWDI1200E	1000 HP AT 2200 RPM / 800 HP AT 1000 RPM	1200 (900)

EIS #	OPTIONAL SMALL MOTOR TEST KIT
280300	10HP AT 1800RPM UP TO 25HP AT 3600RPM
280600	25HP AT 1800RPM UP TO 50HP AT 3600RPM
280900	50HP AT 1800RPM UP TO 75HP AT 3600RPM



# ROTOR TOTOR

- Shaft locking mechanism
- Each unit has leveling adjustment slots
- Spring Mechanism for positive locating in appropriate lifting slot
- Both units are designed to be used as counter balancing tools to remove and install rotors and armatures
- Units will be load tested for 125% of marked capacity



EIS #	WEIGHTED LIFTING CAPACITY (LBS)
RT500-VOL	500
RT1000-VOL	1000

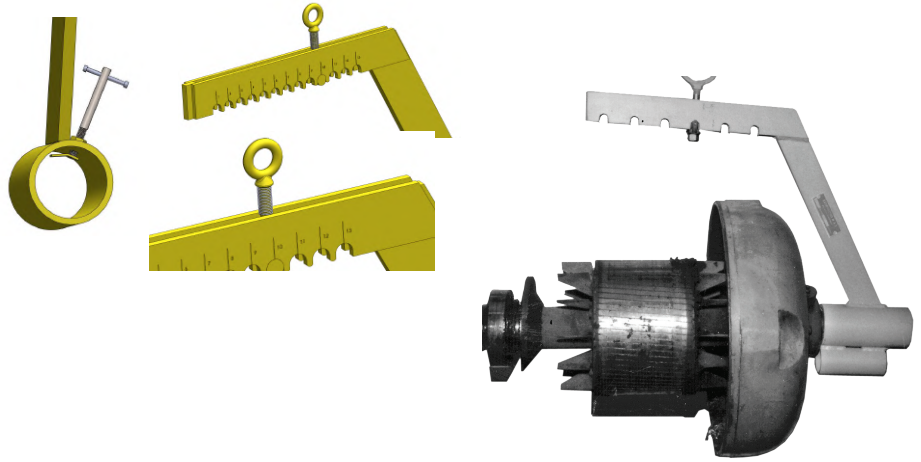

## 9000 LB ADJUSTABLE ROTOR LIFT FIXTURE

EIS# 3298-000

- 9000 lbs capacity
- Adjustable bail - 50" of travel
- Counter balance end weight
- Adjustable rotor shaft clamp - 150mm min to 210mm max
- Adjustable rotor shaft clamp end support - 370mm nom
- Square box end ratchet wrench to adjust clamps
- Designed, certified, and proof tested to meet ASME B30.20

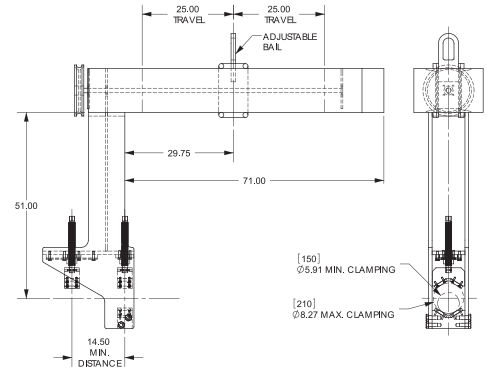

EIS  
2018 Powers Ferry Road SE  
Suite 500  
Atlanta, Georgia 30339-7202

Presorted STD  
US Postage  
PAID  
Permit 39  
Atlanta, GA



Shop online at [EIS-inc.com](http://EIS-inc.com)

