



Spherical roller thrust bearings

Designs	878
SKF Explorer class bearings	878
Bearing data – general	879
Dimensions	879
Tolerances	879
Misalignment	879
Influence of operating temperatures on bearing material	879
Minimum load	880
Equivalent dynamic bearing load	880
Equivalent static bearing load	880
Supplementary designations	880
Design of associated components	881
Lubrication	882
Mounting	883
Product table	884



Designs

In spherical roller thrust bearings the load is transmitted from one raceway to the other at an angle (→ **fig. 1**). The bearings are therefore suitable to accommodate radial loads in addition to simultaneously acting axial loads. Another important characteristic of spherical roller thrust bearings is their self-aligning capability. This makes the bearings insensitive to shaft deflection and misalignment of the shaft relative to the housing.

SKF spherical roller thrust bearings incorporate a large number of asymmetrical rollers and have specially designed raceways with an optimum conformity. They can therefore support very heavy axial loads and permit relatively high speed operation.

Depending on the bearing series and size, SKF spherical roller thrust bearings are produced to two designs. Bearings up to and including size 68 identified by the designation suffix E have a pressed window-type cage of sheet steel. The cage, rollers and shaft washer form a non-separable assembly (→ **fig. 2**). All other bearings have a machined brass or steel cage, which is guided by a sleeve held in the shaft washer bore (→ **fig. 3**). The shaft washer, cage and rollers form a non-separable unit.

SKF Explorer class bearings

High performance SKF Explorer spherical roller thrust bearings are shown with an asterisk in the product table. SKF Explorer bearings retain the designation of the earlier standard bearings, e.g. 29330 E. However, each bearing and its box are marked with the name "EXPLORER".

Fig. 1

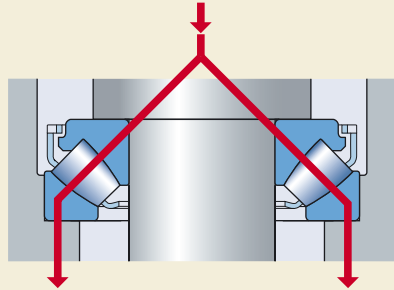

Fig. 2

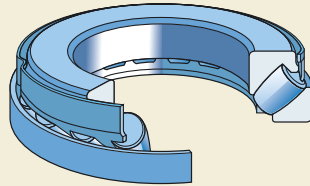
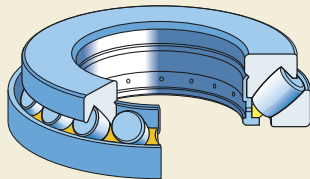

Fig. 3



Bearing data – general

Dimensions

The boundary dimensions of SKF spherical roller thrust bearings are in accordance with ISO 104:2002.

Tolerances

SKF spherical roller thrust bearings are produced as standard to Normal tolerances as specified in ISO 199:1997. However the tolerances for the total height of

- SKF standard bearings are more than 50 % tighter
- SKF Explorer bearings are 75 % tighter

than specified by ISO.

The tolerance values can be found in **table 10** on **page 132**.

Misalignment

By virtue of their design, spherical roller thrust bearings are self-aligning, i.e. they tolerate misalignment of the shaft relative to the housing, and shaft deflections during operation (→ **fig. 4**). Whether the permissible misalignment can be fully exploited depends on the design of the bearing arrangement, the type of seal etc.

The permissible misalignment is reduced as the load increases. The values indicated in **table 1** can be permitted provided there is constant misalignment and a rotating shaft washer. When designing bearing arrangements, it is advisable to contact the SKF application engineering service if the following conditions occur:

- Rotating housing washer in combination with misalignment.
- The shaft wobbles in relation to the housing.

Influence of operating temperatures on bearing material

All SKF spherical roller thrust bearings undergo a special heat treatment so that they can be operated at higher temperatures for longer periods, without the occurrence of inadmissible dimensional changes. For example, a temperature of +200 °C for 2 500 h, or for shorter

Fig. 4

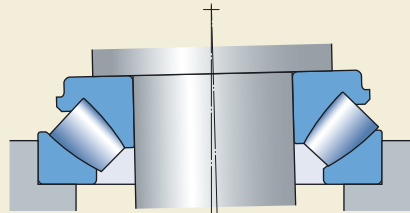

Table 1

Bearing series	Permissible angular misalignment		
	Permissible misalignment when bearing load P_0 ¹⁾		
	< 0,05 C_0	> 0,05 C_0	> 0,3 C_0
–	degrees		
292 (E)	2	1,5	1
293 (E)	2,5	1,5	0,3
294 (E)	3	1,5	0,3

¹⁾ $P_0 = F_a + 2,7 F_r$

periods at even higher temperatures, is permitted.

Spherical roller thrust bearings

Minimum load

In order to provide satisfactory operation, spherical roller thrust bearings, like all ball and roller bearings, must always be subjected to a given minimum load, particularly if they are to operate at high speeds or are subjected to high accelerations or rapid changes in the direction of the load. Under such conditions, the inertia forces of the rollers and cage, and the friction in the lubricant, can have a detrimental influence on the rolling conditions in the bearing arrangement and may cause damaging sliding movements to occur between the rollers and raceways.

The requisite minimum axial load to be applied to spherical roller thrust bearings can be estimated using

$$F_{am} = 1,8 F_r + A \left(\frac{n}{1000} \right)^2$$

where

F_{am} = minimum axial load, kN

F_r = radial component of the load for bearings subjected to combined load, kN

C_0 = basic static load rating, kN
(→ product table)

A = minimum load factor
(→ product table)

n = rotational speed, r/min

If $1,8 F_r < 0,0005 C_0$ then $0,0005 C_0$ should be used in the above equation instead of $1,8 F_r$.

At speeds higher than the reference speed or when starting up at low temperatures, or when the lubricant is highly viscous, even greater minimum loads may be required. The weight of the components supported by the bearing, together with external forces, generally exceeds the requisite minimum load. If this is not the case, the spherical roller thrust bearing must be preloaded, e.g. by springs. For additional information, contact the SKF application engineering service.

Equivalent dynamic bearing load

Normally a spherical roller thrust bearing is arranged so that runouts in the bearing arrangement do not affect the load distribution in the bearing. For a spherical roller thrust bear-

ing arranged under these conditions, provided $F_r \leq 0,55 F_a$.

$$P = 0,88 (F_a + 1,2 F_r)$$

When runouts in the bearing arrangement affect the load distribution in the spherical roller thrust bearing, provided $F_r \leq 0,55 F_a$

$$P = F_a + 1,2 F_r$$

If $F_r > 0,55 F_a$, the SKF application engineering service should be contacted.

Equivalent static bearing load

$$P_0 = F_a + 2,7 F_r$$

provided $F_r \leq 0,55 F_a$. If $F_r > 0,55 F_a$, the SKF application engineering service should be contacted.

Supplementary designations

The designation suffixes used to identify certain features of SKF spherical roller thrust bearings are explained in the following.

- E** Optimized internal design and pressed window-type steel cage
- EF** Optimized internal design and machined steel cage
- EM** Optimized internal design and machined brass cage
- N1** One locating slot in the housing washer
- N2** Two locating slots 180° apart in the housing washer
- VE447** Shaft washer with three equally spaced threaded holes in one side face to take hoisting tackle
- VE447E** Shaft washer with three equally spaced threaded holes in one side face to take hoisting tackle and three appropriate eye bolts
- VE632** Housing washer with three equally spaced threaded holes in one side face to take hoisting tackle

Design of associated components

The abutment dimensions d_a and D_a in the product table apply for bearing loads up to approximately $F_a = 0,1 C_0$. Where bearings are to be subjected to heavier loads it may be necessary for both shaft and housing washers to be fully supported ($d_a = d_1$ and $D_a = D_1$) and for radial support to be provided for the housing washer. For additional information, contact the SKF application engineering service.

For E-design bearings with a pressed steel cage, the housing bore must be recessed (→ **fig. 5**) to prevent the cage from rubbing against the housing if the shaft should become misaligned. Recommended guideline values for the diameter of this recess are

- $D + 15$ mm for bearings with outside diameter up to and including 380 mm and
- $D + 20$ mm for larger bearings.

Fig. 5

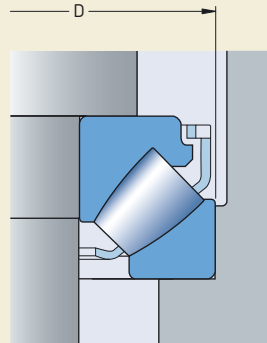

Lubrication

Generally lubrication with oil or grease containing EP additives is recommended for spherical roller thrust bearings.

When lubricating with grease the roller end/flange contacts must be supplied with an adequate amount of lubricant. Depending on the application, this can best be done by completely filling the bearing and its housing with grease, or by regular relubrication.

Because of their internal design, spherical roller thrust bearings have a pumping action that can be taken advantage of, in order to provide circulation of the lubricating oil when

- the shaft is vertical (→ **fig. 6**) or
- the shaft is horizontal (→ **fig. 7**).

The pumping action must be considered when selecting lubricants and seals.

For more detailed information about the lubrication of spherical roller thrust bearings contact the SKF application engineering service.

Fig. 6

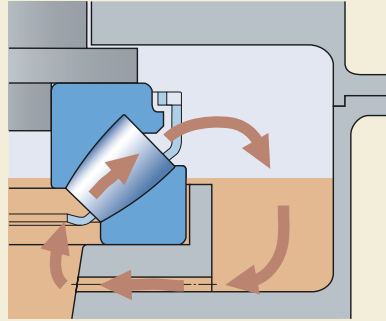
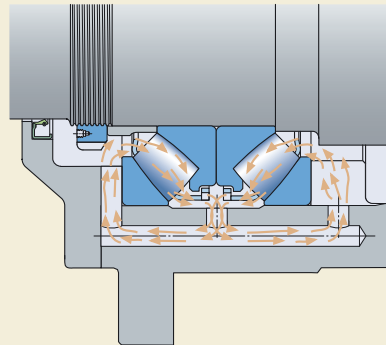

Fig. 7



Mounting

SKF spherical roller thrust bearings are of separable design, i.e. the shaft washer with cage and roller assembly can be mounted separately from the housing washer.

If bearings of earlier design with a machined cage, where the cage-guiding sleeve also served as spacer sleeve, are to be replaced by E-design bearings, a spacer sleeve is needed between the shaft washer and the existing abutment (→ **fig. 8**).

If earlier B-design bearings, which were mounted with a spacer sleeve, are to be replaced, the sleeve must be checked and re-machined if necessary (→ **fig. 9**). The sleeves must be hardened and should have ground end faces; the recommended sleeve outside diameter is provided for each bearing in the product table.

Fig. 8

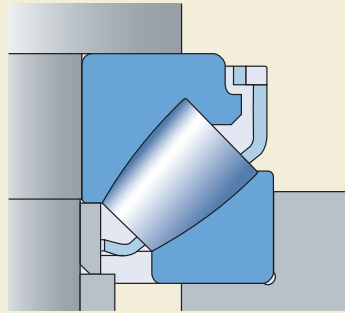
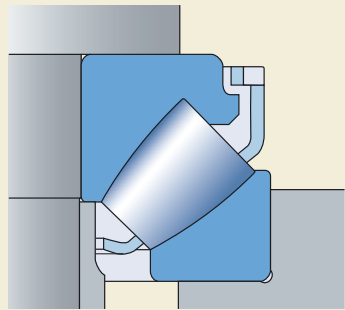
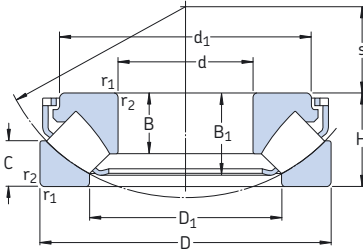

Fig. 9



Spherical roller thrust bearings
d 60 – 170 mm



Principal dimensions			Basic load ratings		Fatigue load limit P_u	Minimum load factor A	Speed ratings		Mass	Designation
d	D	H	dynamic	static C_0			Reference speed	Limiting speed		
mm			kN		kN	–	r/min	kg	–	
60	130	42	390	915	114	0,080	2 800	5 000	2,20	* 29412 E
65	140	45	455	1 080	137	0,11	2 600	4 800	3,20	* 29413 E
70	150	48	520	1 250	153	0,15	2 400	4 300	3,90	* 29414 E
75	160	51	600	1 430	173	0,19	2 400	4 000	4,70	* 29415 E
80	170	54	670	1 630	193	0,25	2 200	3 800	5,60	* 29416 E
85	150 180	39 58	380 735	1 060 1 800	129 212	0,11 0,31	2 400 2 000	4 000 3 600	2,75 6,75	* 29317 E * 29417 E
90	155 190	39 60	400 815	1 080 2 000	132 232	0,11 0,38	2 400 1 900	4 000 3 400	2,85 7,75	* 29318 E * 29418 E
100	170 210	42 67	465 980	1 290 2 500	156 275	0,16 0,59	2 200 1 700	3 600 3 000	3,65 10,5	* 29320 E * 29420 E
110	190 230	48 73	610 1 180	1 730 3 000	204 325	0,28 0,86	1 900 1 600	3 200 2 800	5,30 13,5	* 29322 E * 29422 E
120	210 250	54 78	765 1 370	2 120 3 450	245 375	0,43 1,1	1 700 1 500	2 800 2 600	7,35 17,5	* 29324 E * 29424 E
130	225 270	58 85	865 1 560	2 500 4 050	280 430	0,59 1,6	1 600 1 300	2 600 2 400	9,00 22,0	* 29326 E * 29426 E
140	240 280	60 85	980 1 630	2 850 4 300	315 455	0,77 1,8	1 500 1 300	2 600 2 400	10,5 23,0	* 29328 E * 29428 E
150	215 250 300	39 60 90	408 1 000 1 860	1 600 2 850 5 100	180 315 520	0,24 0,77 2,5	1 800 1 500 1 200	2 800 2 400 2 200	4,30 11,0 28,0	29230 E * 29330 E * 29430 E
160	270 320	67 95	1 180 2 080	3 450 5 600	375 570	1,1 3	1 300 1 100	2 200 2 000	14,5 33,5	* 29332 E * 29432 E
170	280 340	67 103	1 200 2 360	3 550 6 550	365 640	1,2 4,1	1 300 1 100	2 200 1 900	15,0 44,5	* 29334 E * 29434 E

* SKF Explorer bearing

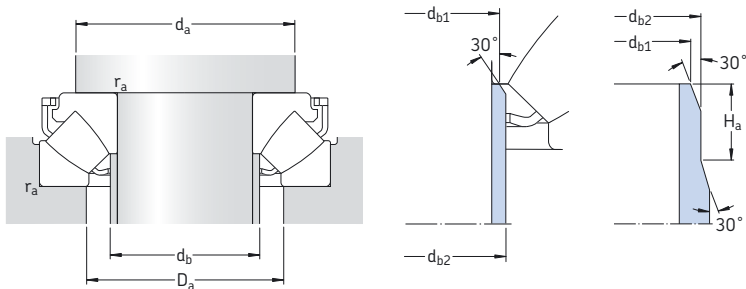
Dimensions
Abutment and fillet dimensions

d	d ₁	D ₁	B	B ₁	C	r _{1,2} min	s	d _a min	d _{b1} max	d _{b2} max	H _a min	D _a max	r _a max
mm	mm	mm	mm	mm	mm	mm	mm	mm	mm	mm	mm	mm	mm
60	112,2	85,5	27	36,7	21	1,5	38	90	67	67	–	107	1,5
65	120,6	91,5	29,5	39,8	22	2	42	100	72	72	–	117	2
70	129,7	99	31	41	23,8	2	44,8	105	77,5	77,5	–	125	2
75	138,3	105,5	33,5	45,7	24,5	2	47	115	82,5	82,5	–	133	2
80	147,2	112,5	35	48,1	26,5	2,1	50	120	88	88	–	141	2
85	134,8 155,8	109,5 121	24,5 37	33,8 51,1	20 28	1,5 2,1	50 54	115 130	90 94	90 94	–	129 151	1,5 2
90	138,6 164,6	115 127,5	24,5 39	34,5 54	19,5 28,5	1,5 2,1	53 56	120 135	95 99	95 99	–	134 158	1,5 2
100	152,3 182,2	127,5 141,5	26,2 43	36,3 57,3	20,5 32	1,5 3	58 62	130 150	107 110	107 110	–	147 175	1,5 2,5
110	171,1 199,4	140 155,5	30,3 47	41,7 64,7	24,8 34,7	2 3	63,8 69	145 165	117 120,5	117 129	–	164 193	2 2,5
120	188,1 216,8	154 171	34 50,5	48,2 70,3	27 36,5	2,1 4	70 74	160 180	128 132	128 142	–	181 209	2 3
130	203,4 234,4	165,5 184,5	36,7 54	50,6 76	30,1 40,9	2,1 4	75,6 81	175 195	138 142,5	143 153	–	194 227	2 3
140	216,1 245,4	177 194,5	38,5 54	54 75,6	30 41	2,1 4	82 86	185 205	148 153	154 162	–	208 236	2 3
150	200,4 223,9 262,9	176 190 207,5	24 38 58	34,3 54,9 80,8	20,5 28 43,4	1,5 2,1 4	82 87 92	180 195 220	154 158 163	154 163 175	14	193 219 253	1,5 2 3
160	243,5 279,3	203 223,5	42 60,5	60 84,3	33 45,5	3 5	92 99	210 235	169 175	176 189	–	235 270	2,5 4
170	251,2 297,7	215 236	42,2 65,5	61 91,2	30,5 50	3 5	96 104	220 250	178 185	188 199	–	245 286	2,5 4

Spherical roller thrust bearings
d 180 – 340 mm

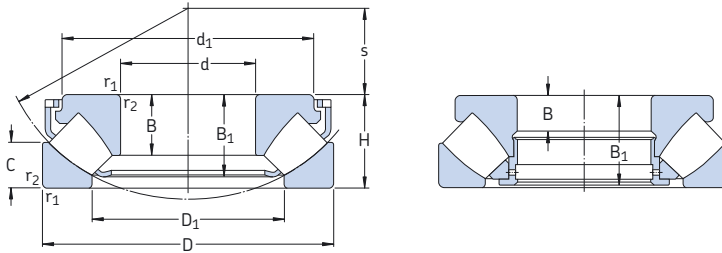

E design

Principal dimensions			Basic load ratings		Fatigue load limit P_u	Minimum load factor A	Speed ratings		Mass	Designation
d	D	H	C	C_0			Refer- ence speed	Limiting speed		
mm			kN		kN	–	r/min	kg	–	
180	250	42	495	2 040	212	0,40	1 600	2 600	5,80	29236 E
	300	73	1 430	4 300	440	1,8	1 200	2 000	19,5	* 29336 E
	360	109	2 600	7 350	710	5,1	1 000	1 800	52,5	* 29436 E
190	320	78	1 630	4 750	490	2,1	1 100	1 900	23,5	* 29338 E
	380	115	2 850	8 000	765	6,1	950	1 700	60,5	* 29438 E
200	280	48	656	2 650	285	0,67	1 400	2 200	9,30	29240 E
	340	85	1 860	5 500	550	2,9	1 000	1 700	29,5	* 29340 E
	400	122	3 200	9 000	850	7,7	850	1 600	72,0	* 29440 E
220	300	48	690	3 000	310	0,86	1 300	2 200	10,0	29244 E
	360	85	2 000	6 300	610	3,8	1 000	1 700	33,5	* 29344 E
	420	122	3 350	9 650	900	8,8	850	1 500	75,0	* 29444 E
240	340	60	799	3 450	335	1,1	1 100	1 800	16,5	29248
	380	85	2 040	6 550	630	4,1	1 000	1 600	35,5	* 29348 E
	440	122	3 400	10 200	930	9,9	850	1 500	80,0	* 29448 E
260	360	60	817	3 650	345	1,3	1 100	1 700	18,5	29252
	420	95	2 550	8 300	780	6,5	850	1 400	49,0	* 29352 E
	480	132	4 050	12 900	1 080	16	750	1 300	105	* 29452 E
280	380	60	863	4 000	375	1,5	1 000	1 700	19,5	29256
	440	95	2 550	8 650	800	7,1	850	1 400	53,0	* 29356 E
	520	145	4 900	15 300	1 320	22	670	1 200	135	* 29456 E
300	420	73	1 070	4 800	465	2,2	900	1 400	30,5	29260
	480	109	3 100	10 600	930	11	750	1 200	75,0	* 29360 E
	540	145	4 310	16 600	1 340	26	600	1 200	140	29460 E
320	440	73	1 110	5 100	465	2,5	850	1 400	33,0	29264
	500	109	3 350	11 200	1 000	12	750	1 200	78,0	* 29364 E
	580	155	4 950	19 000	1 530	34	560	1 100	175	29464 E
340	460	73	1 130	5 400	480	2,8	850	1 300	33,5	29268
	540	122	2 710	11 000	950	11	600	1 100	105	29368
	620	170	5 750	22 400	1 760	48	500	1 000	220	29468 E

* SKF Explorer bearing

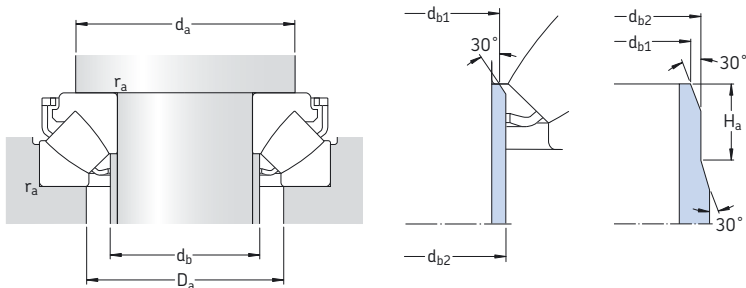

Dimensions
Abutment and fillet dimensions

d	d ₁	D ₁	B	B ₁	C	r _{1,2}	s	d _a	d _{b1}	d _{b2}	H _a	D _a	r _a
mm	-	-				min		min	max	max	min	max	max
180	234,4	208	26	36,9	22	1,5	97	210	187	187	14	226	1,5
	270	227	46	66,2	35,5	3	103	235	189	195	-	262	2,5
	315,9	250	69,5	96,4	53	5	110	265	196	210	-	304	4
190	285,6	243,5	49	71,3	36	4	110	250	200	211	-	280	3
	332,9	264,5	73	101	55,5	5	117	280	207	223	-	321	4
200	260,5	232,5	30	43,4	24	2	108	235	206	207	17	253	2
	304,3	257	53,5	76,7	40	4	116	265	211	224	-	297	3
	350,7	277,5	77	107,1	59,4	5	122	295	217,5	234	-	337	4
220	280,5	251,5	30	43,4	24,5	2	117	255	224,5	227	17	271	2
	326,3	273,5	55	77,7	41	4	125	285	229	240	-	316	3
	371,6	300	77	107,4	58,5	6	132	315	238	254	-	358	5
240	330	283	19	57	30	2,1	130	290	-	-	-	308	2
	345,1	295,5	54	77,8	40,5	4	135	305	249	259	-	336	3
	391,6	322	76	107,1	59	6	142	335	258	276	-	378	5
260	350	302	19	57	30	2,1	139	310	-	-	-	326	2
	382,2	324	61	86,6	46	5	148	335	273	286	-	370	4
	427,9	346	86	119	63	6	154	365	278	296	-	412	5
280	370	323	19	57	30,5	2,1	150	325	-	-	-	347	2
	401	343	62	86,7	45,5	5	158	355	293	305	-	390	4
	464,3	372	95	129,9	70	6	166	395	300	320	-	446	5
300	405	353	21	69	38	3	162	360	-	-	-	380	2,5
	434,1	372	70	98,9	51	5	168	385	313	329	-	423	4
	485	392	95	130,3	70,5	6	175	415	319	340	-	465	5
320	430	372	21	69	38	3	172	380	-	-	-	400	2,5
	454,5	391	68	97,8	53	5	180	405	332	347	-	442	4
	520,3	422	102	139,4	74,5	7,5	191	450	344	367	-	500	6
340	445	395	21	69	37,5	3	183	400	-	-	-	422	2,5
	520	428	40,6	117	59,5	5	192	440	-	-	-	479	4
	557,9	445	112	151,4	84	7,5	201	475	363	386	-	530	6

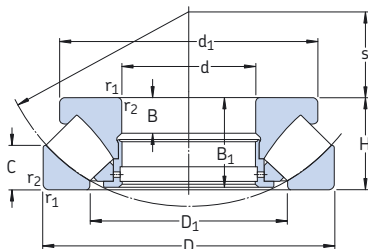
Spherical roller thrust bearings
d 360 – 560 mm

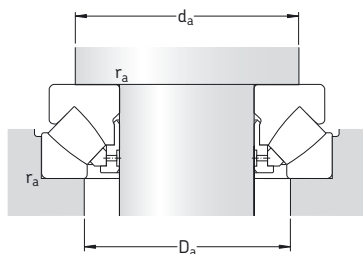

Principal dimensions			Basic load ratings		Fatigue load limit P_u	Minimum load factor A	Speed ratings		Mass	Designation
d	D	H	C	C_0			Refer- ence speed	Limiting speed		
mm			kN		kN	–	r/min	kg	–	
360	500	85	1 460	6 800	585	4,4	750	1 200	52,0	29272
	560	122	2 760	11 600	980	13	600	1 100	110	29372
	640	170	5 350	21 200	1 630	43	500	950	230	29472 EM
380	520	85	1 580	7 650	655	5,6	700	1 100	53,0	29276
	600	132	3 340	14 000	1 160	19	530	1 000	140	29376
	670	175	5 870	24 000	1 860	55	480	900	260	29476 EM
400	540	85	1 610	8 000	695	6,1	700	1 100	55,5	29280
	620	132	3 450	14 600	1 200	20	530	950	150	29380
	710	185	6 560	26 500	1 960	67	450	850	310	29480 EM
420	580	95	1 990	9 800	815	9,1	630	1 000	75,5	29284
	650	140	3 740	16 000	1 290	24	500	900	170	29384
	730	185	6 730	27 500	2 080	72	430	850	325	29484 EM
440	600	95	2 070	10 400	850	10	630	1 000	78,0	29288
	680	145	4 490	19 300	1 560	35	480	850	180	29388 EM
	780	206	7 820	32 000	2 320	87	380	750	410	29488 EM
460	620	95	2 070	10 600	865	11	600	950	81,0	29292
	710	150	4 310	19 000	1 500	34	450	800	215	29392
	800	206	7 990	33 500	2 450	110	380	750	425	29492 EM
480	650	103	2 350	11 800	950	13	560	900	98,0	29296
	730	150	4 370	19 600	1 530	36	450	800	220	29396
	850	224	9 550	39 000	2 800	140	340	670	550	29496 EM
500	670	103	2 390	12 500	1 000	15	560	900	100	292/500
	750	150	4 490	20 400	1 560	40	430	800	235	293/500
	870	224	9 370	40 000	2 850	150	340	670	560	294/500 EM
530	710	109	3 110	15 300	1 220	22	530	850	115	292/530 EM
	800	160	5 230	23 600	1 800	53	400	750	270	293/530
	920	236	10 500	44 000	3 100	180	320	630	650	294/530 EM
560	750	115	2 990	16 000	1 220	24	480	800	140	292/560
	980	250	12 000	51 000	3 550	250	300	560	810	294/560 EM



Dimensions

Abutment and fillet dimensions

d	d_1	D_1	B	B_1	C	$r_{1,2}$	s	d_a	D_a	r_a
	~	~				min		min	max	max
mm								mm		
360	485	423	25	81	44	4	194,5	430	453	3
	540	448	40,5	117	59,5	5	202	460	500	4
	580	474	63	164	83,5	7,5	210	495	550	6
380	505	441	27	81	42	4	202	450	473	3
	580	477	45	127	63,5	6	216	495	535	5
	610	494	67	168	87,5	7,5	222	525	580	6
400	526	460	27	81	42,2	4	212	470	493	3
	596	494	43	127	64	6	225	510	550	5
	645	525	69	178	89,5	7,5	234	550	615	6
420	564	489	30	91	46	5	225	500	525	4
	626	520	49	135	67,5	6	235	535	580	5
	665	545	70	178	90,5	7,5	244	575	635	6
440	585	508	30	91	46,5	5	235	520	545	4
	626	540	49	140	70,5	6	249	560	605	5
	710	577	77	199	101	9,5	257	605	675	8
460	605	530	30	91	46	5	245	540	565	4
	685	567	50	144	72,5	6	257	585	630	5
	730	596	77	199	101,5	9,5	268	630	695	8
480	635	556	33	99	53,5	5	259	570	595	4
	705	591	50	144	73,5	6	270	610	655	5
	770	625	88	216	108	9,5	280	660	735	8
500	654	574	33	99	53,5	5	268	585	615	4
	725	611	50	144	74	6	280	630	675	5
	795	648	86	216	110	9,5	290	685	755	8
530	675	608	32	105	56	5	285	620	655	4
	772	648	53	154	76	7,5	295	670	715	6
	840	686	89	228	116	9,5	308	725	800	8
560	732	644	37	111	61	5	302	655	685	4
	890	727	99	241	122	12	328	770	850	10

Spherical roller thrust bearings

d 600 – 1 600 mm

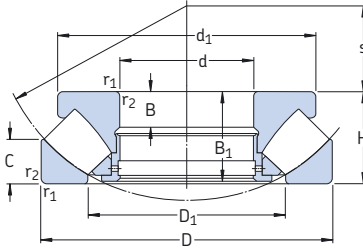

Principal dimensions			Basic load ratings		Fatigue load limit P_u	Minimum load factor A	Speed ratings		Mass	Designation
d	D	H	C	C_0			Refer- ence speed	Limiting speed		
mm			kN		kN	-	r/min		kg	-
600	800	122	3 740	18 600	1 460	33	450	700	170	292/600 EM
	900	180	7 530	34 500	2 600	110	340	630	405	293/600
	1 030	258	13 100	56 000	4 000	300	280	530	845	294/600 EM
630	850	132	4 770	23 600	1 800	53	400	670	210	292/630 EM
	950	190	8 450	38 000	2 900	140	320	600	485	293/630 EM
	1 090	280	14 400	62 000	4 150	370	260	500	1 040	294/630 EM
670	900	140	4 200	22 800	1 660	49	380	630	255	292/670
	1 150	290	15 400	68 000	4 500	440	240	450	1 210	294/670 EM
710	1 060	212	9 950	45 500	3 400	200	280	500	660	293/710 EM
	1 220	308	17 600	76 500	5 000	560	220	430	1 500	294/710 EF
750	1 000	150	6 100	31 000	2 320	91	340	560	325	292/750 EM
	1 120	224	9 370	45 000	3 050	190	260	480	770	293/750
	1 280	315	18 700	85 000	5 500	690	200	400	1 650	294/750 EF
800	1 060	155	6 560	34 500	2 550	110	320	530	380	292/800 EM
	1 180	230	9 950	49 000	3 250	230	240	450	865	293/800
	1 360	335	20 200	93 000	5 850	820	190	360	2 025	294/800 EF
850	1 120	160	6 730	36 000	2 550	120	300	500	425	292/850 EM
	1 440	354	23 900	108 000	7 100	1 100	170	340	2 390	294/850 EF
900	1 520	372	26 700	122 000	7 200	1 400	160	300	2 650	294/900 EF
950	1 250	180	8 280	45 500	3 100	200	260	430	600	292/950 EM
	1 600	390	28 200	132 000	7 800	1 700	140	280	3 065	294/950 EF
1 000	1 670	402	31 100	140 000	8 650	1 900	130	260	3 380	294/1000 EF
1 060	1 400	206	10 500	58 500	3 750	330	220	360	860	292/1060 EF
	1 770	426	33 400	156 000	8 500	2 300	120	240	4 280	294/1060 EF
1 180	1 520	206	10 900	64 000	3 750	390	220	340	950	292/1180 EF
1 250	1 800	330	24 800	129 000	7 500	1 600	130	240	2 770	293/1250 EF
1 600	2 280	408	36 800	200 000	11 800	3 800	90	160	5 375	293/1600 EF

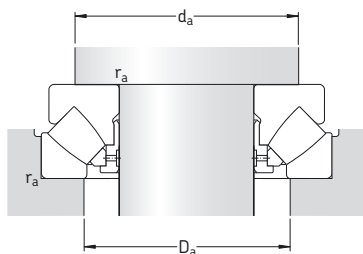
Dimensions
Abutment and fillet dimensions

d	d ₁	D ₁	B	B ₁	C	r _{1,2} min	s	d _a min	D _a max	r _a max
mm								mm		
600	760	688	39	117	60	5	321	700	735	4
	840	720	65	174	89	7,5	340	755	810	6
	940	769	99	249	128	12	349	815	900	10
630	810	723	50	127	62	6	338	740	780	5
	880	761	68	183	92	9,5	359	795	860	8
	995	815	107	270	137	12	365	860	950	10
670	880	773	45	135	73	6	361	790	825	5
	1045	864	110	280	141	15	387	905	1000	12
710	985	855	74	205	103	9,5	404	890	960	8
	1110	917	117	298	149	15	415	965	1070	12
750	950	858	50	144	74	6	409	880	925	5
	1086	910	76	216	109	9,5	415	935	1000	8
	1170	964	121	305	153	15	436	1015	1120	12
800	1010	911	52	149	77	7,5	434	935	980	6
	1146	965	77	222	111	9,5	440	995	1060	8
	1250	1034	123	324	165	15	462	1080	1185	12
850	1060	967	47	154	82	7,5	455	980	1030	6
	1315	1077	142	342	172	15	507	1160	1270	12
900	1394	1137	147	360	186	15	518	1215	1320	12
950	1185	1081	58	174	88	7,5	507	1095	1155	6
	1470	1209	153	377	191	15	546	1275	1400	12
1000	1531	1270	155	389	190	15	599	1350	1490	12
1060	1325	1211	66	199	100	9,5	566	1225	1290	8
	1615	1349	192	412	207	15	610	1410	1555	12
1180	1450	1331	83	199	101	9,5	625	1345	1410	8
1250	1685	1474	148	319	161	12	698	1540	1640	10
1600	2130	1885	166	395	195	19	894	1955	2090	15