



NEW
Product
AEGIS® uKIT
see back insert

*Sustainable Technology
for
True Inverter Duty Motors*



2012

Protect Your Motor from Electrical Bearing Damage





BEARING PROTECTION RING

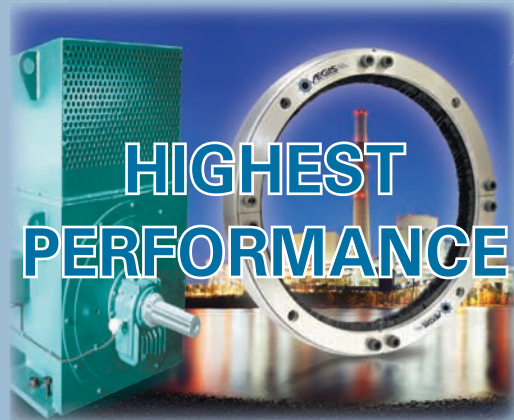

“The only bearing protection system guaranteed to eliminate harmful shaft currents preventing premature motor failure.”



Guarantee

Electro Static Technology guarantees any new motor up to 100hp/75kW will not fail from electrical bearing fluting damage for the expected normal bearing life of the original motor bearings when AEGIS® SGR Bearing Protection Ring is installed in accordance with manufacturer's guarantee requirements. If electrically induced fluting damage occurs, Electro Static Technology will replace motor bearings. Guarantee is subject to the terms and conditions of the AEGIS® SGR Guarantee Program.

For program details, visit: www.est-aegis.com

TABLE OF CONTENTS

Bearing Protection Guarantee	2
AEGIS® Bearing Protection Ring	3
About Shaft Voltages	4
Application Notes	5-6
AEGIS® iPRO	6
Selecting The Right Size	7
AEGIS® Installation Options	8
Parts List - Conductive Epoxy	9
Parts List - Standard, Split, Bolt Through 10-11	
Parts List - Press Fit Installation	12
Parts List - NEMA-IEC Installation Kits	13
AEGIS® Shaft Voltage Probe	14
Colloidal Silver Shaft Coating CS015	14
Conductive Epoxy EP2400	14
Motor Specification	15

Don't let this happen to your bearings!

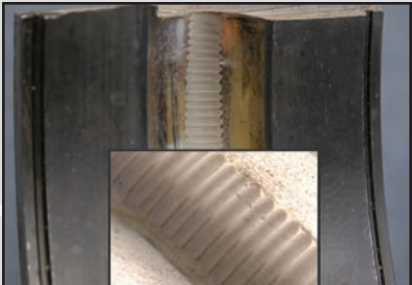

Sustainable Motor Design - Prevent Bearing Failure

AEGIS® Bearing Protection Ring - protects motor bearings for life. Variable frequency drives (VFD) induce electrical voltages onto the shaft of AC and DC motors. With AEGIS® SGR Bearing Protection Ring installed on the motor, you benefit from sustainability, system up-time, production improvement, and higher reliability.

PROBLEM:

VFD Induced Shaft Voltages Damage Bearings

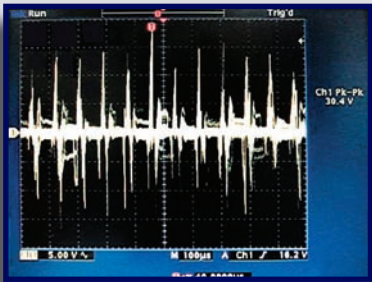

Shaft voltage reading with no protection

Variable frequency drives (VFD) on AC and DC motors induce harmful electrical voltages on the motor shaft. Once these voltages exceed the resistance of the bearing lubricant, they discharge through the motor's bearings causing fusion craters, severe pitting, fluting damage, excessive bearing noise and eventually bearing failure.

SOLUTION:

AEGIS® SGR - Electrical Bearing Damage Protection

The new AEGIS® SGR Bearing Protection Ring prevents electrical bearing damage by safely channeling harmful shaft voltages away from the bearings to ground. Using proprietary Electron Transport Technology™, the conductive micro fibers inside the AEGIS® SGR provide the path of least resistance and dramatically extend motor life.

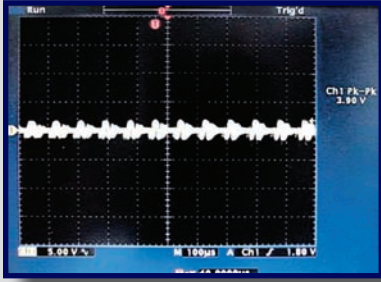

Shaft voltage reading with AEGIS® SGR

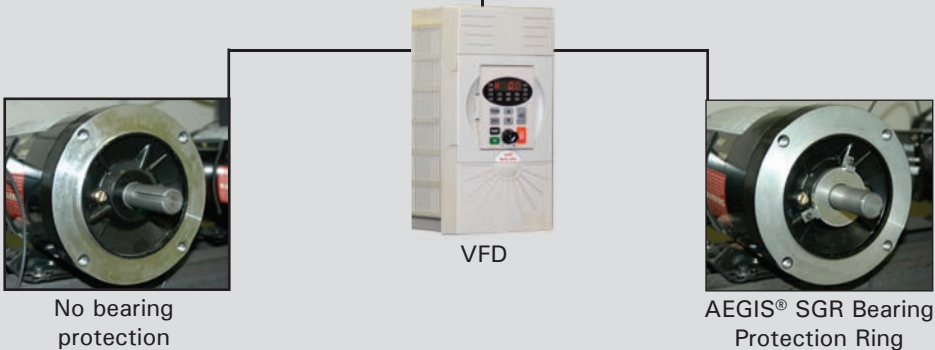

About Shaft Voltages and Bearing Currents

VFD Induced Shaft Voltages - All Motors

Damaging voltages are induced on the shafts of AC and DC motors controlled by variable frequency drives (VFD). The extremely high on/off switching speeds of the pulse width modulation (PWM), generated by the insulated gate bipolar transistors (IGBT), induce damaging voltages onto the motor shaft through parasitic capacitive coupling between the stator and rotor. This common mode shaft voltage seeks a path to ground, usually through the motor's bearings.

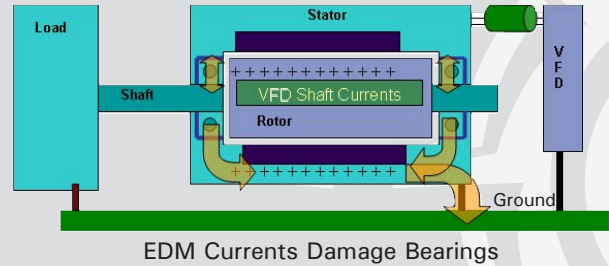

Bearing fluting, "washboard" pattern on bearing race

Electrical Damage in the Bearings (EDM) - Pitting, Fluting, Failure

Damaging currents arc through the dielectric oil film between the rolling elements and the bearing race. This is known as electrical discharge machining (EDM) effect. EDM causes fusion craters, severe pitting, and eventually bearing fluting (a washboard-like pattern in the bearing race) which results in premature bearing failure.

High Frequency Circulating Currents in Large AC and DC Motors

In addition to potential bearing failures in motors from VFD induced EDM currents, AC and DC motors above 100 hp (75 kW) may also experience bearing failures caused by high frequency circulating currents. VFD induced high frequency circulating currents are in the kilohertz or even megahertz range and circulate through the motor's bearings because of magnetic flux imbalances in the stator. This type of VFD induced current becomes the more dominant destructive current in higher hp/kW motors.

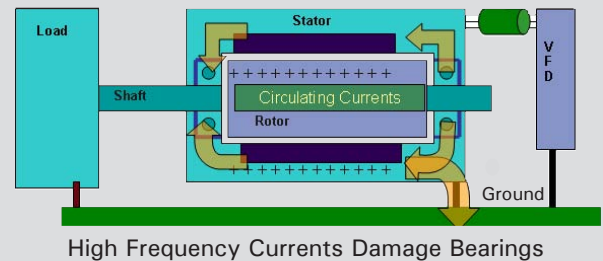

AEGIS® SGR Bearing Protection Ring is the most effective solution to protect bearings in motors and attached equipment from EDM currents and VFD induced shaft voltages.

Technology Comparison

	AEGIS® SGR	Insulating sleeve	Ceramic/Hybrid Bearing	Copper or Bronze Metal Brush	Carbon Block Brush	Conductive Grease
Protects Motor <u>and</u> Attached Equipment	Yes	No	No	No	No	No
Long-term Effectiveness	Yes	No	No	No	No	No
Easy to install	Yes	No	No	No	No	No
Low Lifetime Cost High return on Investment	Yes	No	No	No	No	No
Effective at any RPM	Yes	Yes	Yes	No	No	No
Maintenance Free Operation	Yes	Yes	Yes	No	No	No

Application Notes for AEGIS® Bearing Protection Ring

Improve System Reliability and Production with Sustainable Motor Design

Motors up to 100 HP (75 kW)

Any motor controlled by a variable frequency drive (VFD) requires bearing protection. Motors of 100 hp down to fractional hp motors will experience bearing failures when operated on a PWM drive. AEGIS® SGR Bearing Protection Ring guarantees that bearings will not fail in these motors from fluting damage for the service life of the motor.

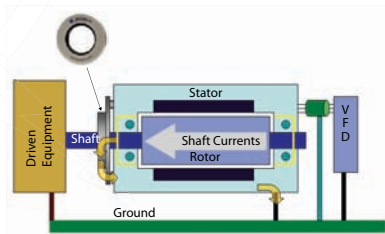

Install one AEGIS® SGR Bearing Protection Ring on either the drive end or the non-drive end of the motor. The simplest installation is to slide the AEGIS® SGR over the drive end and fasten it to the motor end bell with the easy to install mounting hardware included with each AEGIS® SGR

- ★ Recommend Colloidal Silver Shaft Coating PN CS015

Motors 100 HP to 1000 HP (75 kW to 750 kW)

Large motors above 100 hp may have VFD induced EDM currents as well as high frequency circulating currents when they are controlled by VFDs. To protect the bearings, insulate the bearing on one end and install an AEGIS® SGR on the other end.

Insulation on one end (usually NDE) and AEGIS® SGR on opposite end

- Motor frame must be well grounded
- Non-Drive End: Bearing journal should be insulated or Insulated/ Ceramic Bearing installed to disrupt circulating currents
- Install AEGIS® SGR Bearing Protection Ring on opposite end of insulation and Insulated/Ceramic Bearing (usually DE)
- Protects bearings in attached equipment (gear box, pillow block, encoder etc.)
- ★ Recommend Colloidal Silver Shaft Coating PN CS015

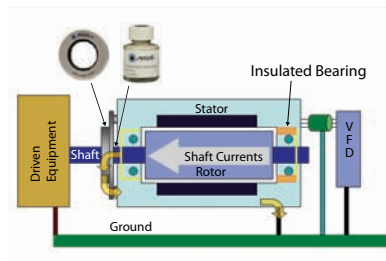

BEARING PROTECTION FACTS:

Bearing protection for motors and attached equipment: Only AEGIS® SGR will protect both motor bearings and the bearings in attached equipment. VFD induced currents on the shaft can discharge through motor bearings or coupled equipment like gear boxes, pumps, fan bearings, pillow blocks, encoders, brake motors, etc. AEGIS® SGR addresses the root of the problem and channels harmful currents to ground.

Maintenance free bearing protection for life: Hundreds of thousands of conductive micro fibers have virtually zero wear during operation, even at high RPM and high surface rates. Unlike carbon block brushes, there is no spring pressure on fibers. AEGIS® SGR Bearing Protection Ring will last for the service life of the motor.

AEGIS® SGR is effective in grease, oil, dirt or dust: Lab and field tested. The conductive micro fibers “sweep” away contaminants from the shaft surface and maintain a conductive path even when oil, grease, dirt or dust get on the shaft.

Operation in harsh environments where fibers are exposed to excessive debris: To prevent particles from damaging the fibers, install a slinger or O-ring against the AEGIS® SGR.

★ COLLOIDAL SILVER SHAFT COATING: NEW TECHNOLOGY

Improving the conductivity of the steel shaft surface enhances the shaft voltage discharge capability in AEGIS® shaft grounding applications. Maintaining a highly conductive shaft surface is especially important in critical applications or in applications where the conductive shaft surface of steel could become compromised. Environmental elements could create a potential for decreased conductivity on the shaft of the motor.



- ★ Recommended for all AEGIS® SGR installations.

BEARING PROTECTION FACTS:

AEGIS® SGR Bearing Protection Ring current handling capability: AEGIS® SGR is rated to discharge high frequency current. Variable frequency drives (VFD) induce high frequency EDM currents of up to 2 amps in 50 billionths of a second. AEGIS® SGR protects the bearing by safely channeling the energy away from the motor bearings to ground.

AEGIS® Bearing Protection Ring - the most reliable bearing protection: Production up-time and reliability improve when AEGIS® SGR is installed. The patented ring of hundreds of thousands of conductive micro fibers provide protection for the service life of the motor. The fibers will always surround the shaft with a conductive path for destructive shaft currents while the motor is running.

Vertical Motors: Insulate top bearing or shaft with non conductive coating. For bottom bearing, coat shaft with Colloidal Silver Shaft Coating and install AEGIS® Bearing Protection Ring.

MOTORS WITH CERAMIC BEARINGS

Insulating both bearing journals or using ceramic coated bearings in the motor **does not prevent VFD induced currents** from discharging through the bearings on attached equipment and may present a voltage hazard.

Whenever ceramic bearings are used in a motor, *AEGIS® SGR is required* to protect attached equipment and reduce potentially dangerous shaft voltages.

Purpose of Application Notes: Application notes are intended as general guidance to assist with proper application of AEGIS® SGR Bearing Protection Ring to protect motor bearings. All statements and technical information contained in the application notes are rendered in good faith. User must assume responsibility to determine suitability of the product for its intended use.

Critical Applications: Insulate both ends and add the AEGIS® SGR Bearing Protection Ring

- Motor frame must be well grounded
- Drive and Non-Drive end: Bearing journals should be insulated or insulated/ceramic bearing installed to disrupt circulating currents
- Install AEGIS® SGR Bearing Protection Ring on drive or non-drive end to provide path of least resistance for shaft voltages and to channel VFD induced currents to ground.
- AEGIS® SGR required to protect bearings in attached equipment (gear box, pillow block, encoder, etc.)
- ★ Coat shaft with AEGIS® Colloidal Silver Shaft Coating

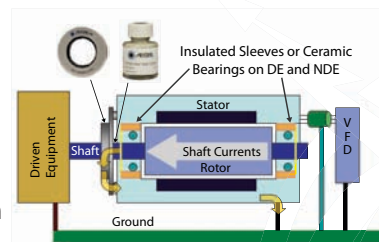

AEGIS® iPRO Bearing Protection Ring High Current Bearing Protection

- Medium Voltage Motors
- Large Motors and Generators over 1000 HP (750 kW)
- Power Generators over 750kW

Large motors and generators often have much higher induced shaft voltages and bearing currents which require a high current capable Bearing Protection Ring. High frequency circulating currents induced by variable frequency drives (VFD) will cause bearing fluting and catastrophic failure in these motors. Generators experience current surges which can cause electrical arcing in bearings and equipment.



Features:

- 6 rows conductive microfiber
- High current capable
- AEGIS® iPRO shaft current monitoring compatible
- Long term reliable performance
- Available in sizes up to 30" (762mm) shaft diameter

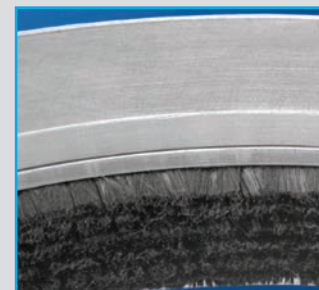

Application:

- One end of the motor should be insulated. Install AEGIS® iPRO on opposite end of insulation to protect the non-insulated bearing.
- ★ Coat shaft with AEGIS® Colloidal Silver Shaft Coating (ships with iPRO)



Conductive Epoxy Mounting

- No drilling or tapping
- Quick and easy installation
- Low profile
- Split or Solid Ring

Selecting The Right Size Bearing Protection Ring For Your Motor



Mounting Options shown on page 8

1. Measure shaft diameter at a point 0.125" from motor end bell.
2. Refer to the part lists to locate the correct SGR part number.

Example shaft measurement
0.425"

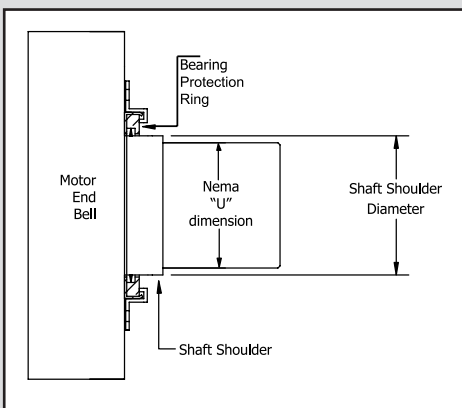

Note: If you have a slinger or a shaft shoulder that is less than 0.375", you will need the NEMA/IEC kit. See page 13 for more information.

Catalog Number	Min. shaft diameter	Max. shaft diameter	Outside diameter	Thickness Max
SGR-6.9-1	0.311	0.355	1.60	0.295
SGR-8.0-1	0.356	0.395	1.60	0.295
SGR-9.0-1	0.396	0.435	1.60	0.295
SGR-10.1-1	0.436	0.480	1.60	0.295
SGR-11.2-1	0.481	0.520	1.60	0.295

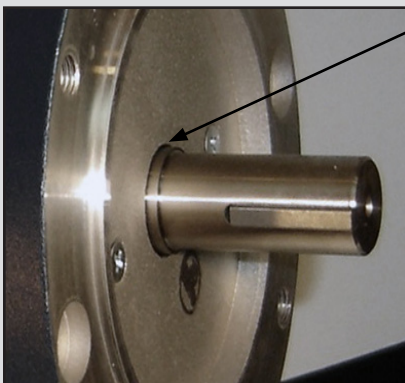

Shaft Shoulder: The standard SGR can be mounted to the shaft shoulder but the shoulder should be at least 0.375" in length so that all of the fibers are in contact with the rotating shaft. Measure the diameter of the shaft shoulder then locate the correct SGR on the part lists.

Custom Option for Short Shaft Shoulders: If the shaft shoulder is between .1875" and 0.375" we offer a custom part. For this option, we place the fibers closer to the back of the ring to allow for fiber contact on a shorter shoulder. To order this option, add an "X" or "AX" to the suffix of the part.

Example:

Standard SGR
 PN: SGR-6.9-0A4W
 PN: SGR-6.9-0AW
 PN: SGR-6.9-1
 PN: SGR-6.9-2A4
 PN: SGR-6.9-3

Short Shoulder SGR
 PN: SGR-6.9-0A4WX
 PN: SGR-6.9-0AWX
 PN: SGR-6.9-1AX
 PN: SGR-6.9-2A4X
 PN: SGR-6.9-3AX

AEGIS® SGR Bearing Protection Ring Options



**NEW PRODUCT!
SEE BACK INSERT**

AEGIS® SGR uKIT with Universal Mounting Bracket

- Sized for NEMA and IEC Frame motors
- Solid and Split Ring
- Can be mounted with hardware or conductive epoxy

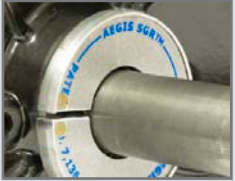

pg. 9

Conductive Epoxy Mounting

- Shaft diameters: 0.311" to 6.02"
- Solid and Split Ring
- Quick and easy installation to metal motor frame
- Conductive Epoxy Included



pg.10-11

Standard Mounting Brackets

- Shaft diameters: 0.311" to 6.02"
- Ships with mounting brackets, 6-32 screws and washers
- Quick and easy installation to most surfaces



pg. 10-11

Split Ring

- Shaft diameter: 0.311" to 6.02"
- 4 to 6 mounting brackets, M3 screws and washers
- Installs without decoupling motor



pg. 10-11

Bolt Through Mounting

- Shaft diameters: 0.311" to 6.02"
- M3 x 14 socket head cap screws and lock washers
- 2 mounting holes up to shaft size 3.895"
- 4 mounting holes for larger sizes



pg. 12

Press Fit Mounting

- Shaft diameters: 0.311" to 6.02"
- Clean dry 0.004" press fit
- Custom sizes available



pg. 13

NEMA-IEC Mounting Kits

- Shaft diameter: see chart for standard kits
- Custom kits available for other shaft diameters
- Clears any slinger, shaft shoulder or protrusion



pg. 14

AEGIS® Accessories

- SVP - AEGIS® Shaft Voltage Probe
- CS015 - AEGIS® Colloidal Silver Shaft Coating
- EP2400 - AEGIS® Conductive Epoxy

AEGIS® SGR - Conductive Epoxy Mounting



AEGIS® SGR and Conductive Epoxy Included

To purchase Conductive Epoxy only, use Catalog Number EP2400

Dimensions in inches

Solid SGR Catalog Number	Split SGR* Catalog Number	Min. shaft diameter	Max. shaft diameter	Outside diameter	Thickness Max	Solid SGR Catalog Number	Split SGR* Catalog Number	Min. shaft diameter	Max. shaft diameter	Outside diameter	Thickness Max
SGR-6.9-0AW	SGR-6.9-0A4W	0.311	0.355	1.60	0.295	SGR-79.9-0AW	SGR-79.9-0A4W	3.186	3.230	4.10	0.295
SGR-8.0-0AW	SGR-8.0-0A4W	0.356	0.395	1.60	0.295	SGR-81.1-0AW	SGR-81.1-0A4W	3.231	3.270	4.10	0.295
SGR-9.0-0AW	SGR-9.0-0A4W	0.396	0.435	1.60	0.295	SGR-82.1-0AW	SGR-82.1-0A4W	3.271	3.310	4.10	0.295
SGR-10.1-0AW	SGR-10.1-0A4W	0.436	0.480	1.60	0.295	SGR-83.1-0AW	SGR-83.1-0A4W	3.311	3.355	4.10	0.295
SGR-11.2-0AW	SGR-11.2-0A4W	0.481	0.520	1.60	0.295	SGR-84.2-0AW	SGR-84.2-0A4W	3.356	3.395	4.10	0.295
SGR-12.2-0AW	SGR-12.2-0A4W	0.521	0.560	1.60	0.295	SGR-85.2-0AW	SGR-85.2-0A4W	3.396	3.435	4.60	0.295
SGR-13.2-0AW	SGR-13.2-0A4W	0.561	0.605	1.60	0.295	SGR-86.3-0AW	SGR-86.3-0A4W	3.436	3.480	4.60	0.295
SGR-14.4-0AW	SGR-14.4-0A4W	0.606	0.645	1.60	0.295	SGR-87.4-0AW	SGR-87.4-0A4W	3.481	3.520	4.60	0.295
SGR-15.4-0AW	SGR-15.4-0A4W	0.646	0.685	2.10	0.295	SGR-88.4-0AW	SGR-88.4-0A4W	3.521	3.560	4.60	0.295
SGR-16.4-0AW	SGR-16.4-0A4W	0.686	0.730	2.10	0.295	SGR-89.4-0AW	SGR-89.4-0A4W	3.561	3.605	4.60	0.295
SGR-17.6-0AW	SGR-17.6-0A4W	0.731	0.774	2.10	0.295	SGR-90.6-0AW	SGR-90.6-0A4W	3.606	3.645	4.60	0.295
SGR-18.7-0AW	SGR-18.7-0A4W	0.775	0.815	2.10	0.295	SGR-91.6-0AW	SGR-91.6-0A4W	3.646	3.685	4.60	0.295
SGR-19.7-0AW	SGR-19.7-0A4W	0.816	0.855	2.10	0.295	SGR-92.6-0AW	SGR-92.6-0A4W	3.686	3.730	4.60	0.295
SGR-20.7-0AW	SGR-20.7-0A4W	0.856	0.895	2.10	0.295	SGR-93.8-0AW	SGR-93.8-0A4W	3.731	3.770	4.60	0.295
SGR-21.7-0AW	SGR-21.7-0A4W	0.896	0.935	2.10	0.295	SGR-94.8-0AW	SGR-94.8-0A4W	3.771	3.810	4.60	0.295
SGR-22.8-0AW	SGR-22.8-0A4W	0.936	0.980	2.10	0.295	SGR-95.8-0AW	SGR-95.8-0A4W	3.811	3.855	4.60	0.295
SGR-23.9-0AW	SGR-23.9-0A4W	0.981	1.020	2.10	0.295	SGR-96.9-0AW	SGR-96.9-0A4W	3.856	3.895	4.60	0.295
SGR-24.9-0AW	SGR-24.9-0A4W	1.021	1.060	2.10	0.295	SGR-97.9-0AW	SGR-97.9-0A4W	3.896	3.935	5.10	0.295
SGR-25.9-0AW	SGR-25.9-0A4W	1.061	1.105	2.10	0.295	SGR-99.0-0AW	SGR-99.0-0A4W	3.936	3.980	5.10	0.295
SGR-27.1-0AW	SGR-27.1-0A4W	1.106	1.145	2.10	0.295	SGR-100.1-0AW	SGR-100.1-0A4W	3.981	4.020	5.10	0.295
SGR-28.1-0AW	SGR-28.1-0A4W	1.146	1.185	2.10	0.295	SGR-101.1-0AW	SGR-101.1-0A4W	4.021	4.060	5.10	0.295
SGR-29.1-0AW	SGR-29.1-0A4W	1.186	1.230	2.10	0.295	SGR-102.1-0AW	SGR-102.1-0A4W	4.061	4.105	5.10	0.295
SGR-30.3-0AW	SGR-30.3-0A4W	1.231	1.270	2.10	0.295	SGR-103.3-0AW	SGR-103.3-0A4W	4.106	4.145	5.10	0.295
SGR-31.3-0AW	SGR-31.3-0A4W	1.271	1.310	2.10	0.295	SGR-104.3-0AW	SGR-104.3-0A4W	4.146	4.185	5.10	0.295
SGR-32.3-0AW	SGR-32.3-0A4W	1.311	1.355	2.10	0.295	SGR-105.3-0AW	SGR-105.3-0A4W	4.186	4.230	5.10	0.295
SGR-33.4-0AW	SGR-33.4-0A4W	1.356	1.395	2.10	0.295	SGR-106.5-0AW	SGR-106.5-0A4W	4.231	4.270	5.10	0.295
SGR-34.4-0AW	SGR-34.4-0A4W	1.396	1.435	2.68	0.295	SGR-107.5-0AW	SGR-107.5-0A4W	4.271	4.310	5.10	0.295
SGR-35.5-0AW	SGR-35.5-0A4W	1.436	1.480	2.68	0.295	SGR-108.5-0AW	SGR-108.5-0A4W	4.311	4.355	5.10	0.295
SGR-36.6-0AW	SGR-36.6-0A4W	1.481	1.520	2.68	0.295	SGR-109.6-0AW	SGR-109.6-0A4W	4.356	4.395	5.10	0.295
SGR-37.6-0AW	SGR-37.6-0A4W	1.521	1.560	2.68	0.295	SGR-110.6-0AW	SGR-110.6-0A4W	4.396	4.435	5.60	0.295
SGR-38.6-0AW	SGR-38.6-0A4W	1.561	1.605	2.68	0.295	SGR-111.7-0AW	SGR-111.7-0A4W	4.436	4.480	5.60	0.295
SGR-39.8-0AW	SGR-39.8-0A4W	1.606	1.645	2.68	0.295	SGR-112.8-0AW	SGR-112.8-0A4W	4.481	4.520	5.60	0.295
SGR-40.8-0AW	SGR-40.8-0A4W	1.646	1.685	2.68	0.295	SGR-113.8-0AW	SGR-113.8-0A4W	4.521	4.560	5.60	0.295
SGR-41.8-0AW	SGR-41.8-0A4W	1.686	1.730	2.68	0.295	SGR-114.8-0AW	SGR-114.8-0A4W	4.561	4.605	5.60	0.295
SGR-43.0-0AW	SGR-43.0-0A4W	1.731	1.770	2.68	0.295	SGR-116.0-0AW	SGR-116.0-0A4W	4.606	4.645	5.60	0.295
SGR-44.0-0AW	SGR-44.0-0A4W	1.771	1.810	2.68	0.295	SGR-117.0-0AW	SGR-117.0-0A4W	4.646	4.685	5.60	0.295
SGR-45.0-0AW	SGR-45.0-0A4W	1.811	1.855	2.68	0.295	SGR-118.0-0AW	SGR-118.0-0A4W	4.686	4.730	5.60	0.295
SGR-46.1-0AW	SGR-46.1-0A4W	1.856	1.895	2.68	0.295	SGR-119.2-0AW	SGR-119.2-0A4W	4.731	4.770	5.60	0.295
SGR-47.1-0AW	SGR-47.1-0A4W	1.896	1.935	2.68	0.295	SGR-120.2-0AW	SGR-120.2-0A4W	4.771	4.810	5.60	0.295
SGR-48.2-0AW	SGR-48.2-0A4W	1.936	1.980	2.68	0.295	SGR-121.2-0AW	SGR-121.2-0A4W	4.811	4.855	5.60	0.295
SGR-49.3-0AW	SGR-49.3-0A4W	1.981	2.020	2.68	0.295	SGR-122.3-0AW	SGR-122.3-0A4W	4.856	4.895	5.60	0.295
SGR-50.3-0AW	SGR-50.3-0A4W	2.021	2.060	3.10	0.295	SGR-123.3-0AW	SGR-123.3-0A4W	4.896	4.935	6.10	0.295
SGR-51.3-0AW	SGR-51.3-0A4W	2.061	2.105	3.10	0.295	SGR-124.4-0AW	SGR-124.4-0A4W	4.936	4.980	6.10	0.295
SGR-52.5-0AW	SGR-52.5-0A4W	2.106	2.145	3.10	0.295	SGR-125.5-0AW	SGR-125.5-0A4W	4.981	5.020	6.10	0.295
SGR-53.5-0AW	SGR-53.5-0A4W	2.146	2.185	3.10	0.295	SGR-126.5-0AW	SGR-126.5-0A4W	5.021	5.060	6.10	0.295
SGR-54.5-0AW	SGR-54.5-0A4W	2.186	2.230	3.10	0.295	SGR-127.5-0AW	SGR-127.5-0A4W	5.061	5.105	6.10	0.295
SGR-55.7-0AW	SGR-55.7-0A4W	2.231	2.270	3.10	0.295	SGR-128.7-0AW	SGR-128.7-0A4W	5.106	5.145	6.10	0.295
SGR-56.7-0AW	SGR-56.7-0A4W	2.271	2.310	3.10	0.295	SGR-129.7-0AW	SGR-129.7-0A4W	5.146	5.185	6.10	0.295
SGR-57.7-0AW	SGR-57.7-0A4W	2.311	2.355	3.10	0.295	SGR-130.7-0AW	SGR-130.7-0A4W	5.186	5.230	6.10	0.295
SGR-58.8-0AW	SGR-58.8-0A4W	2.356	2.395	3.10	0.295	SGR-131.9-0AW	SGR-131.9-0A4W	5.231	5.270	6.10	0.295
SGR-59.8-0AW	SGR-59.8-0A4W	2.396	2.435	3.60	0.295	SGR-132.9-0AW	SGR-132.9-0A4W	5.271	5.310	6.10	0.295
SGR-60.9-0AW	SGR-60.9-0A4W	2.436	2.480	3.60	0.295	SGR-133.9-0AW	SGR-133.9-0A4W	5.311	5.355	6.10	0.295
SGR-62.0-0AW	SGR-62.0-0A4W	2.481	2.520	3.60	0.295	SGR-135.0-0AW	SGR-135.0-0A4W	5.356	5.395	6.10	0.295
SGR-63.0-0AW	SGR-63.0-0A4W	2.521	2.560	3.60	0.295	SGR-136.0-0AW	SGR-136.0-0A4W	5.396	5.435	6.60	0.295
SGR-64.0-0AW	SGR-64.0-0A4W	2.561	2.605	3.60	0.295	SGR-137.1-0AW	SGR-137.1-0A4W	5.436	5.480	6.60	0.295
SGR-65.2-0AW	SGR-65.2-0A4W	2.606	2.645	3.60	0.295	SGR-138.2-0AW	SGR-138.2-0A4W	5.481	5.520	6.60	0.295
SGR-66.2-0AW	SGR-66.2-0A4W	2.646	2.685	3.60	0.295	SGR-139.2-0AW	SGR-139.2-0A4W	5.521	5.560	6.60	0.295
SGR-67.2-0AW	SGR-67.2-0A4W	2.686	2.730	3.60	0.295	SGR-140.2-0AW	SGR-140.2-0A4W	5.561	5.605	6.60	0.295
SGR-68.4-0AW	SGR-68.4-0A4W	2.731	2.770	3.60	0.295	SGR-141.4-0AW	SGR-141.4-0A4W	5.606	5.645	6.60	0.295
SGR-69.4-0AW	SGR-69.4-0A4W	2.771	2.810	3.60	0.295	SGR-142.4-0AW	SGR-142.4-0A4W	5.646	5.685	6.60	0.295
SGR-70.4-0AW	SGR-70.4-0A4W	2.811	2.855	3.60	0.295	SGR-143.4-0AW	SGR-143.4-0A4W	5.686	5.730	6.60	0.295
SGR-71.5-0AW	SGR-71.5-0A4W	2.856	2.895	3.60	0.295	SGR-144.6-0AW	SGR-144.6-0A4W	5.731	5.770	6.60	0.295
SGR-72.5-0AW	SGR-72.5-0A4W	2.896	2.935	4.10	0.295	SGR-145.6-0AW	SGR-145.6-0A4W	5.771	5.810	6.60	0.295
SGR-73.6-0AW	SGR-73.6-0A4W	2.936	2.980	4.10	0.295	SGR-146.6-0AW	SGR-146.6-0A4W	5.811	5.855	6.60	0.295
SGR-74.7-0AW	SGR-74.7-0A4W	2.981	3.020	4.10	0.295	SGR-147.7-0AW	SGR-147.7-0A4W	5.856	5.895	6.60	0.295
SGR-75.7-0AW	SGR-75.7-0A4W	3.021	3.060	4.10	0.295	SGR-148.7-0AW	SGR-148.7-0A4W	5.896	5.935	7.10	0.295
SGR-76.7-0AW	SGR-76.7-0A4W	3.061	3.105	4.10	0.295	SGR-149.8-0AW	SGR-149.8-0A4W	5.936	5.980	7.10	0.295
SGR-77.9-0AW	SGR-77.9-0A4W	3.106	3.145	4.10	0.295	SGR-150.9-0AW	SGR-150.9-0A4W	5.981	6.020	7.10	0.295
SGR-78.9-0AW	SGR-78.9-0A4W	3.146	3.185	4.10	0.295						

Conductive Epoxy Included

*Custom Part - No Returns

Standard, Split Ring, and Bolt Through Mounting



Dimensions in inches

Standard SGR Catalog Number	Split Ring* Catalog Number	Bolt Through* Catalog Number	Min. shaft diameter	Max. shaft diameter	Outside diameter	Thickness Max
SGR-6.9-1	SGR-6.9-2A4	SGR-6.9-3	0.311	0.355	1.60	0.295
SGR-8.0-1	SGR-8.0-2A4	SGR-8.0-3	0.356	0.395	1.60	0.295
SGR-9.0-1	SGR-9.0-2A4	SGR-9.0-3	0.396	0.435	1.60	0.295
SGR-10.1-1	SGR-10.1-2A4	SGR-10.1-3	0.436	0.480	1.60	0.295
SGR-11.2-1	SGR-11.2-2A4	SGR-11.2-3	0.481	0.520	1.60	0.295
SGR-12.2-1	SGR-12.2-2A4	SGR-12.2-3	0.521	0.560	1.60	0.295
SGR-13.2-1	SGR-13.2-2A4	SGR-13.2-3	0.561	0.605	1.60	0.295
SGR-14.4-1	SGR-14.4-2A4	SGR-14.4-3	0.606	0.645	1.60	0.295
SGR-15.4-1	SGR-15.4-2A4	SGR-15.4-3	0.646	0.685	2.10	0.295
SGR-16.4-1	SGR-16.4-2A4	SGR-16.4-3	0.686	0.730	2.10	0.295
SGR-17.6-1	SGR-17.6-2A4	SGR-17.6-3	0.731	0.774	2.10	0.295
SGR-18.7-1	SGR-18.7-2A4	SGR-18.7-3	0.775	0.815	2.10	0.295
SGR-19.7-1	SGR-19.7-2A4	SGR-19.7-3	0.816	0.855	2.10	0.295
SGR-20.7-1	SGR-20.7-2A4	SGR-20.7-3	0.856	0.895	2.10	0.295
SGR-21.7-1	SGR-21.7-2A4	SGR-21.7-3	0.896	0.935	2.10	0.295
SGR-22.8-1	SGR-22.8-2A4	SGR-22.8-3	0.936	0.980	2.10	0.295
SGR-23.9-1	SGR-23.9-2A4	SGR-23.9-3	0.981	1.020	2.10	0.295
SGR-24.9-1	SGR-24.9-2A4	SGR-24.9-3	1.021	1.060	2.10	0.295
SGR-25.9-1	SGR-25.9-2A4	SGR-25.9-3	1.061	1.105	2.10	0.295
SGR-27.1-1	SGR-27.1-2A4	SGR-27.1-3	1.106	1.145	2.10	0.295
SGR-28.1-1	SGR-28.1-2A4	SGR-28.1-3	1.146	1.185	2.10	0.295
SGR-29.1-1	SGR-29.1-2A4	SGR-29.1-3	1.186	1.230	2.10	0.295
SGR-30.3-1	SGR-30.3-2A4	SGR-30.3-3	1.231	1.270	2.10	0.295
SGR-31.3-1	SGR-31.3-2A4	SGR-31.3-3	1.271	1.310	2.10	0.295
SGR-32.3-1	SGR-32.3-2A4	SGR-32.3-3	1.311	1.355	2.10	0.295
SGR-33.4-1	SGR-33.4-2A4	SGR-33.4-3	1.356	1.395	2.10	0.295
SGR-34.4-1	SGR-34.4-2A4	SGR-34.4-3	1.396	1.435	2.68	0.295
SGR-35.5-1	SGR-35.5-2A4	SGR-35.5-3	1.436	1.480	2.68	0.295
SGR-36.6-1	SGR-36.6-2A4	SGR-36.6-3	1.481	1.520	2.68	0.295
SGR-37.6-1	SGR-37.6-2A4	SGR-37.6-3	1.521	1.560	2.68	0.295
SGR-38.6-1	SGR-38.6-2A4	SGR-38.6-3	1.561	1.605	2.68	0.295
SGR-39.8-1	SGR-39.8-2A4	SGR-39.8-3	1.606	1.645	2.68	0.295
SGR-40.8-1	SGR-40.8-2A4	SGR-40.8-3	1.646	1.685	2.68	0.295
SGR-41.8-1	SGR-41.8-2A4	SGR-41.8-3	1.686	1.730	2.68	0.295
SGR-43.0-1	SGR-43.0-2A4	SGR-43.0-3	1.731	1.770	2.68	0.295
SGR-44.0-1	SGR-44.0-2A4	SGR-44.0-3	1.771	1.810	2.68	0.295
SGR-45.0-1	SGR-45.0-2A4	SGR-45.0-3	1.811	1.855	2.68	0.295
SGR-46.1-1	SGR-46.1-2A4	SGR-46.1-3	1.856	1.895	2.68	0.295
SGR-47.1-1	SGR-47.1-2A4	SGR-47.1-3	1.896	1.935	2.68	0.295
SGR-48.2-1	SGR-48.2-2A4	SGR-48.2-3	1.936	1.980	2.68	0.295
SGR-49.3-1	SGR-49.3-2A4	SGR-49.3-3	1.981	2.020	2.68	0.295
SGR-50.3-1	SGR-50.3-2A4	SGR-50.3-3	2.021	2.060	3.10	0.295
SGR-51.3-1	SGR-51.3-2A4	SGR-51.3-3	2.061	2.105	3.10	0.295
SGR-52.5-1	SGR-52.5-2A4	SGR-52.5-3	2.106	2.145	3.10	0.295
SGR-53.5-1	SGR-53.5-2A4	SGR-53.5-3	2.146	2.185	3.10	0.295
SGR-54.5-1	SGR-54.5-2A4	SGR-54.5-3	2.186	2.230	3.10	0.295
SGR-55.7-1	SGR-55.7-2A4	SGR-55.7-3	2.231	2.270	3.10	0.295
SGR-56.7-1	SGR-56.7-2A4	SGR-56.7-3	2.271	2.310	3.10	0.295
SGR-57.7-1	SGR-57.7-2A4	SGR-57.7-3	2.311	2.355	3.10	0.295
SGR-58.8-1	SGR-58.8-2A4	SGR-58.8-3	2.356	2.395	3.10	0.295
SGR-59.8-1	SGR-59.8-2A4	SGR-59.8-3	2.396	2.435	3.60	0.295
SGR-60.9-1	SGR-60.9-2A4	SGR-60.9-3	2.436	2.480	3.60	0.295
SGR-62.0-1	SGR-62.0-2A4	SGR-62.0-3	2.481	2.520	3.60	0.295
SGR-63.0-1	SGR-63.0-2A4	SGR-63.0-3	2.521	2.560	3.60	0.295
SGR-64.0-1	SGR-64.0-2A4	SGR-64.0-3	2.561	2.605	3.60	0.295
SGR-65.2-1	SGR-65.2-2A4	SGR-65.2-3	2.606	2.645	3.60	0.295
SGR-66.2-1	SGR-66.2-2A4	SGR-66.2-3	2.646	2.685	3.60	0.295
SGR-67.2-1	SGR-67.2-2A4	SGR-67.2-3	2.686	2.730	3.60	0.295
SGR-68.4-1	SGR-68.4-2A4	SGR-68.4-3	2.731	2.770	3.60	0.295
SGR-69.4-1	SGR-69.4-2A4	SGR-69.4-3	2.771	2.810	3.60	0.295
SGR-70.4-1	SGR-70.4-2A4	SGR-70.4-3	2.811	2.855	3.60	0.295
SGR-71.5-1	SGR-71.5-2A4	SGR-71.5-3	2.856	2.895	3.60	0.295
SGR-72.5-1	SGR-72.5-2A4	SGR-72.5-3	2.896	2.935	4.10	0.295
SGR-73.6-1	SGR-73.6-2A4	SGR-73.6-3	2.936	2.980	4.10	0.295
SGR-74.7-1	SGR-74.7-2A4	SGR-74.7-3	2.981	3.020	4.10	0.295
SGR-75.7-1	SGR-75.7-2A4	SGR-75.7-3	3.021	3.060	4.10	0.295
SGR-76.7-1	SGR-76.7-2A4	SGR-76.7-3	3.061	3.105	4.10	0.295
SGR-77.9-1	SGR-77.9-2A4	SGR-77.9-3	3.106	3.145	4.10	0.295
SGR-78.9-1	SGR-78.9-2A4	SGR-78.9-3	3.146	3.185	4.10	0.295

*Custom Part - No Returns

Standard, Split Ring, and Bolt Through Mounting



Dimensions in inches

Standard SGR Catalog Number	Split Ring* Catalog Number	Bolt Through* Catalog Number	Min. shaft diameter	Max. shaft diameter	Outside diameter	Thickness Max
SGR-79.9-1	SGR-79.9-2A4	SGR-79.9-3	3.186	3.230	4.10	0.295
SGR-81.1-1	SGR-81.1-2A4	SGR-81.1-3	3.231	3.270	4.10	0.295
SGR-82.1-1	SGR-82.1-2A4	SGR-82.1-3	3.271	3.310	4.10	0.295
SGR-83.1-1	SGR-83.1-2A4	SGR-83.1-3	3.311	3.355	4.10	0.295
SGR-84.2-1	SGR-84.2-2A4	SGR-84.2-3	3.356	3.395	4.10	0.295
SGR-85.2-1	SGR-85.2-2A4	SGR-85.2-3	3.396	3.435	4.60	0.295
SGR-86.3-1	SGR-86.3-2A4	SGR-86.3-3	3.436	3.480	4.60	0.295
SGR-87.4-1	SGR-87.4-2A4	SGR-87.4-3	3.481	3.520	4.60	0.295
SGR-88.4-1	SGR-88.4-2A4	SGR-88.4-3	3.521	3.560	4.60	0.295
SGR-89.4-1	SGR-89.4-2A4	SGR-89.4-3	3.561	3.605	4.60	0.295
SGR-90.6-1	SGR-90.6-2A4	SGR-90.6-3	3.606	3.645	4.60	0.295
SGR-91.6-1	SGR-91.6-2A4	SGR-91.6-3	3.646	3.685	4.60	0.295
SGR-92.6-1	SGR-92.6-2A4	SGR-92.6-3	3.686	3.730	4.60	0.295
SGR-93.8-1	SGR-93.8-2A4	SGR-93.8-3	3.731	3.770	4.60	0.295
SGR-94.8-1	SGR-94.8-2A4	SGR-94.8-3	3.771	3.810	4.60	0.295
SGR-95.8-1	SGR-95.8-2A4	SGR-95.8-3	3.811	3.855	4.60	0.295
SGR-96.9-1	SGR-96.9-2A4	SGR-96.9-3	3.856	3.895	4.60	0.295
SGR-97.9-1	SGR-97.9-2A4	SGR-97.9-3	3.896	3.935	5.10	0.295
SGR-99.0-1	SGR-99.0-2A4	SGR-99.0-3	3.936	3.980	5.10	0.295
SGR-100.1-1	SGR-100.1-2A4	SGR-100.1-3	3.981	4.020	5.10	0.295
SGR-101.1-1	SGR-101.1-2A4	SGR-101.1-3	4.021	4.060	5.10	0.295
SGR-102.1-1	SGR-102.1-2A4	SGR-102.1-3	4.061	4.105	5.10	0.295
SGR-103.3-1	SGR-103.3-2A4	SGR-103.3-3	4.106	4.145	5.10	0.295
SGR-104.3-1	SGR-104.3-2A4	SGR-104.3-3	4.146	4.185	5.10	0.295
SGR-105.3-1	SGR-105.3-2A4	SGR-105.3-3	4.186	4.230	5.10	0.295
SGR-106.5-1	SGR-106.5-2A4	SGR-106.5-3	4.231	4.270	5.10	0.295
SGR-107.5-1	SGR-107.5-2A4	SGR-107.5-3	4.271	4.310	5.10	0.295
SGR-108.5-1	SGR-108.5-2A4	SGR-108.5-3	4.311	4.355	5.10	0.295
SGR-109.6-1	SGR-109.6-2A4	SGR-109.6-3	4.356	4.395	5.10	0.295
SGR-110.6-1	SGR-110.6-2A4	SGR-110.6-3	4.396	4.435	5.60	0.295
SGR-111.7-1	SGR-111.7-2A4	SGR-111.7-3	4.436	4.480	5.60	0.295
SGR-112.8-1	SGR-112.8-2A4	SGR-112.8-3	4.481	4.520	5.60	0.295
SGR-113.8-1	SGR-113.8-2A4	SGR-113.8-3	4.521	4.560	5.60	0.295
SGR-114.8-1	SGR-114.8-2A4	SGR-114.8-3	4.561	4.605	5.60	0.295
SGR-116.0-1	SGR-116.0-2A4	SGR-116.0-3	4.606	4.645	5.60	0.295
SGR-117.0-1	SGR-117.0-2A4	SGR-117.0-3	4.646	4.685	5.60	0.295
SGR-118.0-1	SGR-118.0-2A4	SGR-118.0-3	4.686	4.730	5.60	0.295
SGR-119.2-1	SGR-119.2-2A4	SGR-119.2-3	4.731	4.770	5.60	0.295
SGR-120.2-1	SGR-120.2-2A4	SGR-120.2-3	4.771	4.810	5.60	0.295
SGR-121.2-1	SGR-121.2-2A4	SGR-121.2-3	4.811	4.855	5.60	0.295
SGR-122.3-1	SGR-122.3-2A4	SGR-122.3-3	4.856	4.895	5.60	0.295
SGR-123.3-1	SGR-123.3-2A4	SGR-123.3-3	4.896	4.935	6.10	0.295
SGR-124.4-1	SGR-124.4-2A4	SGR-124.4-3	4.936	4.980	6.10	0.295
SGR-125.5-1	SGR-125.5-2A4	SGR-125.5-3	4.981	5.020	6.10	0.295
SGR-126.5-1	SGR-126.5-2A4	SGR-126.5-3	5.021	5.060	6.10	0.295
SGR-127.5-1	SGR-127.5-2A4	SGR-127.5-3	5.061	5.105	6.10	0.295
SGR-128.7-1	SGR-128.7-2A4	SGR-128.7-3	5.106	5.145	6.10	0.295
SGR-129.7-1	SGR-129.7-2A4	SGR-129.7-3	5.146	5.185	6.10	0.295
SGR-130.7-1	SGR-130.7-2A4	SGR-130.7-3	5.186	5.230	6.10	0.295
SGR-131.9-1	SGR-131.9-2A4	SGR-131.9-3	5.231	5.270	6.10	0.295
SGR-132.9-1	SGR-132.9-2A4	SGR-132.9-3	5.271	5.310	6.10	0.295
SGR-133.9-1	SGR-133.9-2A4	SGR-133.9-3	5.311	5.355	6.10	0.295
SGR-135.0-1	SGR-135.0-2A4	SGR-135.0-3	5.356	5.395	6.10	0.295
SGR-136.0-1	SGR-136.0-2A4	SGR-136.0-3	5.396	5.435	6.60	0.295
SGR-137.1-1	SGR-137.1-2A4	SGR-137.1-3	5.436	5.480	6.60	0.295
SGR-138.2-1	SGR-138.2-2A4	SGR-138.2-3	5.481	5.520	6.60	0.295
SGR-139.2-1	SGR-139.2-2A4	SGR-139.2-3	5.521	5.560	6.60	0.295
SGR-140.2-1	SGR-140.2-2A4	SGR-140.2-3	5.561	5.605	6.60	0.295
SGR-141.4-1	SGR-141.4-2A4	SGR-141.4-3	5.606	5.645	6.60	0.295
SGR-142.4-1	SGR-142.4-2A4	SGR-142.4-3	5.646	5.685	6.60	0.295
SGR-143.4-1	SGR-143.4-2A4	SGR-143.4-3	5.686	5.730	6.60	0.295
SGR-144.6-1	SGR-144.6-2A4	SGR-144.6-3	5.731	5.770	6.60	0.295
SGR-145.6-1	SGR-145.6-2A4	SGR-145.6-3	5.771	5.810	6.60	0.295
SGR-146.6-1	SGR-146.6-2A4	SGR-146.6-3	5.811	5.855	6.60	0.295
SGR-147.7-1	SGR-147.7-2A4	SGR-147.7-3	5.856	5.895	6.60	0.295
SGR-148.7-1	SGR-148.7-2A4	SGR-148.7-3	5.896	5.935	7.10	0.295
SGR-149.8-1	SGR-149.8-2A4	SGR-149.8-3	5.936	5.980	7.10	0.295
SGR-150.9-1	SGR-150.9-2A4	SGR-150.9-3	5.981	6.020	7.10	0.295

*Custom Part - No Returns

AEGIS® SGR - Press Fit Mounting*



Dimensions in inches

Catalog Number	Min. shaft diameter	Max. shaft diameter	SGR OD Tolerance +0/-0.001	Thickness Max	Bore Tolerance +0.001/-0	Catalog Number	Min. shaft diameter	Max. shaft diameter	SGR OD Tolerance +0/-0.001	Thickness Max	Bore Tolerance +0.001/-0
SGR-6.9-0A6	0.311	0.355	1.580	0.295	1.576	SGR-79.9-0A6	3.186	3.230	4.080	0.295	4.076
SGR-8.0-0A6	0.356	0.395	1.580	0.295	1.576	SGR-81.1-0A6	3.231	3.270	4.080	0.295	4.076
SGR-9.0-0A6	0.396	0.435	1.580	0.295	1.576	SGR-82.1-0A6	3.271	3.310	4.080	0.295	4.076
SGR-10.1-0A6	0.436	0.480	1.580	0.295	1.576	SGR-83.1-0A6	3.311	3.355	4.080	0.295	4.076
SGR-11.2-0A6	0.481	0.520	1.580	0.295	1.576	SGR-84.2-0A6	3.356	3.395	4.080	0.295	4.076
SGR-12.2-0A6	0.521	0.560	1.580	0.295	1.576	SGR-85.2-0A6	3.396	3.435	4.580	0.295	4.576
SGR-13.2-0A6	0.561	0.605	1.580	0.295	1.576	SGR-86.3-0A6	3.436	3.480	4.580	0.295	4.576
SGR-14.4-0A6	0.606	0.645	1.580	0.295	1.576	SGR-87.4-0A6	3.481	3.520	4.580	0.295	4.576
SGR-15.4-0A6	0.646	0.685	2.080	0.295	2.076	SGR-88.4-0A6	3.521	3.560	4.580	0.295	4.576
SGR-16.4-0A6	0.686	0.730	2.080	0.295	2.076	SGR-89.4-0A6	3.561	3.605	4.580	0.295	4.576
SGR-17.6-0A6	0.731	0.774	2.080	0.295	2.076	SGR-90.6-0A6	3.606	3.645	4.580	0.295	4.576
SGR-18.7-0A6	0.775	0.815	2.080	0.295	2.076	SGR-91.6-0A6	3.646	3.685	4.580	0.295	4.576
SGR-19.7-0A6	0.816	0.855	2.080	0.295	2.076	SGR-92.6-0A6	3.686	3.730	4.580	0.295	4.576
SGR-20.7-0A6	0.856	0.895	2.080	0.295	2.076	SGR-93.8-0A6	3.731	3.770	4.580	0.295	4.576
SGR-21.7-0A6	0.896	0.935	2.080	0.295	2.076	SGR-94.8-0A6	3.771	3.810	4.580	0.295	4.576
SGR-22.8-0A6	0.936	0.980	2.080	0.295	2.076	SGR-95.8-0A6	3.811	3.855	4.580	0.295	4.576
SGR-23.9-0A6	0.981	1.020	2.080	0.295	2.076	SGR-96.9-0A6	3.856	3.895	4.580	0.295	4.576
SGR-24.9-0A6	1.021	1.060	2.080	0.295	2.076	SGR-97.9-0A6	3.896	3.935	5.080	0.295	5.076
SGR-25.9-0A6	1.061	1.105	2.080	0.295	2.076	SGR-99.0-0A6	3.936	3.980	5.080	0.295	5.076
SGR-27.1-0A6	1.106	1.145	2.080	0.295	2.076	SGR-100.1-0A6	3.981	4.020	5.080	0.295	5.076
SGR-28.1-0A6	1.146	1.185	2.080	0.295	2.076	SGR-101.1-0A6	4.021	4.060	5.080	0.295	5.076
SGR-29.1-0A6	1.186	1.230	2.080	0.295	2.076	SGR-102.1-0A6	4.061	4.105	5.080	0.295	5.076
SGR-30.3-0A6	1.231	1.270	2.080	0.295	2.076	SGR-103.3-0A6	4.106	4.145	5.080	0.295	5.076
SGR-31.3-0A6	1.271	1.310	2.080	0.295	2.076	SGR-104.3-0A6	4.146	4.185	5.080	0.295	5.076
SGR-32.3-0A6	1.311	1.355	2.080	0.295	2.076	SGR-105.3-0A6	4.186	4.230	5.080	0.295	5.076
SGR-33.4-0A6	1.356	1.395	2.080	0.295	2.076	SGR-106.5-0A6	4.231	4.270	5.080	0.295	5.076
SGR-34.4-0A6	1.396	1.435	2.660	0.295	2.656	SGR-107.5-0A6	4.271	4.310	5.080	0.295	5.076
SGR-35.5-0A6	1.436	1.480	2.660	0.295	2.656	SGR-108.5-0A6	4.311	4.355	5.080	0.295	5.076
SGR-36.6-0A6	1.481	1.520	2.660	0.295	2.656	SGR-109.6-0A6	4.356	4.395	5.080	0.295	5.076
SGR-37.6-0A6	1.521	1.560	2.660	0.295	2.656	SGR-110.6-0A6	4.396	4.435	5.580	0.295	5.576
SGR-38.6-0A6	1.561	1.605	2.660	0.295	2.656	SGR-111.7-0A6	4.436	4.480	5.580	0.295	5.576
SGR-39.8-0A6	1.606	1.645	2.660	0.295	2.656	SGR-112.8-0A6	4.481	4.520	5.580	0.295	5.576
SGR-40.8-0A6	1.646	1.685	2.660	0.295	2.656	SGR-113.8-0A6	4.521	4.560	5.580	0.295	5.576
SGR-41.8-0A6	1.686	1.730	2.660	0.295	2.656	SGR-114.8-0A6	4.561	4.605	5.580	0.295	5.576
SGR-43.0-0A6	1.731	1.770	2.660	0.295	2.656	SGR-116.0-0A6	4.606	4.645	5.580	0.295	5.576
SGR-44.0-0A6	1.771	1.810	2.660	0.295	2.656	SGR-117.0-0A6	4.646	4.685	5.580	0.295	5.576
SGR-45.0-0A6	1.811	1.855	2.660	0.295	2.656	SGR-118.0-0A6	4.686	4.730	5.580	0.295	5.576
SGR-46.1-0A6	1.856	1.895	2.660	0.295	2.656	SGR-119.2-0A6	4.731	4.770	5.580	0.295	5.576
SGR-47.1-0A6	1.896	1.935	2.660	0.295	2.656	SGR-120.2-0A6	4.771	4.810	5.580	0.295	5.576
SGR-48.2-0A6	1.936	1.980	2.660	0.295	2.656	SGR-121.2-0A6	4.811	4.855	5.580	0.295	5.576
SGR-49.3-0A6	1.981	2.020	2.660	0.295	2.656	SGR-122.3-0A6	4.856	4.895	5.580	0.295	5.576
SGR-50.3-0A6	2.021	2.060	3.080	0.295	3.076	SGR-123.3-0A6	4.896	4.935	6.080	0.295	6.076
SGR-51.3-0A6	2.061	2.105	3.080	0.295	3.076	SGR-124.4-0A6	4.936	4.980	6.080	0.295	6.076
SGR-52.5-0A6	2.106	2.145	3.080	0.295	3.076	SGR-125.5-0A6	4.981	5.020	6.080	0.295	6.076
SGR-53.5-0A6	2.146	2.185	3.080	0.295	3.076	SGR-126.5-0A6	5.021	5.060	6.080	0.295	6.076
SGR-54.5-0A6	2.186	2.230	3.080	0.295	3.076	SGR-127.5-0A6	5.061	5.105	6.080	0.295	6.076
SGR-55.7-0A6	2.231	2.270	3.080	0.295	3.076	SGR-128.7-0A6	5.106	5.145	6.080	0.295	6.076
SGR-56.7-0A6	2.271	2.310	3.080	0.295	3.076	SGR-129.7-0A6	5.146	5.185	6.080	0.295	6.076
SGR-57.7-0A6	2.311	2.355	3.080	0.295	3.076	SGR-130.7-0A6	5.186	5.230	6.080	0.295	6.076
SGR-58.8-0A6	2.356	2.395	3.080	0.295	3.076	SGR-131.9-0A6	5.231	5.270	6.080	0.295	6.076
SGR-59.8-0A6	2.396	2.435	3.580	0.295	3.576	SGR-132.9-0A6	5.271	5.310	6.080	0.295	6.076
SGR-60.9-0A6	2.436	2.480	3.580	0.295	3.576	SGR-133.9-0A6	5.311	5.355	6.080	0.295	6.076
SGR-62.0-0A6	2.481	2.520	3.580	0.295	3.576	SGR-135.0-0A6	5.356	5.395	6.080	0.295	6.076
SGR-63.0-0A6	2.521	2.560	3.580	0.295	3.576	SGR-136.0-0A6	5.396	5.435	6.580	0.295	6.576
SGR-64.0-0A6	2.561	2.605	3.580	0.295	3.576	SGR-137.1-0A6	5.436	5.480	6.580	0.295	6.576
SGR-65.2-0A6	2.606	2.645	3.580	0.295	3.576	SGR-138.2-0A6	5.481	5.520	6.580	0.295	6.576
SGR-66.2-0A6	2.646	2.685	3.580	0.295	3.576	SGR-139.2-0A6	5.521	5.560	6.580	0.295	6.576
SGR-67.2-0A6	2.686	2.730	3.580	0.295	3.576	SGR-140.2-0A6	5.561	5.605	6.580	0.295	6.576
SGR-68.4-0A6	2.731	2.770	3.580	0.295	3.576	SGR-141.4-0A6	5.606	5.645	6.580	0.295	6.576
SGR-69.4-0A6	2.771	2.810	3.580	0.295	3.576	SGR-142.4-0A6	5.646	5.685	6.580	0.295	6.576
SGR-70.4-0A6	2.811	2.855	3.580	0.295	3.576	SGR-143.4-0A6	5.686	5.730	6.580	0.295	6.576
SGR-71.5-0A6	2.856	2.895	3.580	0.295	3.576	SGR-144.6-0A6	5.731	5.770	6.580	0.295	6.576
SGR-72.5-0A6	2.896	2.935	4.080	0.295	4.076	SGR-145.6-0A6	5.771	5.810	6.580	0.295	6.576
SGR-73.6-0A6	2.936	2.980	4.080	0.295	4.076	SGR-146.6-0A6	5.811	5.855	6.580	0.295	6.576
SGR-74.7-0A6	2.981	3.020	4.080	0.295	4.076	SGR-147.7-0A6	5.856	5.895	6.580	0.295	6.576
SGR-75.7-0A6	3.021	3.060	4.080	0.295	4.076	SGR-148.7-0A6	5.896	5.935	7.080	0.295	7.076
SGR-76.7-0A6	3.061	3.105	4.080	0.295	4.076	SGR-149.8-0A6	5.936	5.980	7.080	0.295	7.076
SGR-77.9-0A6	3.106	3.145	4.080	0.295	4.076	SGR-150.9-0A6	5.981	6.020	7.080	0.295	7.076
SGR-78.9-0A6	3.146	3.185	4.080	0.295	4.076						

*Custom Part - No Returns

Bearing Protection Ring Kit for NEMA & IEC Motors

Kits include AEGIS® SGR Bearing Protection Ring and all mounting hardware

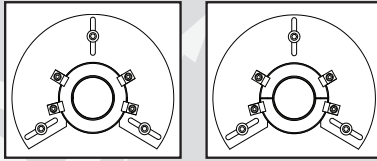

NEMA Motors Solid	NEMA Motors Split	Motor shaft diameter "u"	NEMA Frame	Plate OD
SGR-0.625-NEMA	SGR-0.625-NEMA-1A4	0.625"	56	3.75"
SGR-0.875-NEMA	SGR-0.875-NEMA-1A4	0.875"	143T, 145T	5.60"
SGR-1.125-NEMA	SGR-1.125-NEMA-1A4	1.125"	182T, 184T	5.60"
SGR-1.375-NEMA	SGR-1.375-NEMA-1A4	1.375"	213T, 215T	5.60"
SGR-1.625-NEMA	SGR-1.625-NEMA-1A4	1.625"	254T, 256T	6.30"
SGR-1.875-NEMA	SGR-1.875-NEMA-1A4	1.875"	284T, 286T, 324TS, 326TS, 364TS, 365TS	6.30"
SGR-2.125-NEMA	SGR-2.125-NEMA-1A4	2.125"	324T, 326T, 404TS, 405TS	6.60"
SGR-2.375-NEMA	SGR-2.375-NEMA-1A4	2.375"	364T, 365T, 444TS, 445TS, 447TS, 449TS	6.60"
SGR-2.875-NEMA	SGR-2.875-NEMA-1A4	2.875"	404T, 405T	7.30"
SGR-3.375-NEMA	SGR-3.375-NEMA-1A4	3.375"	444T, 445T, 447T, 449T	7.60"

IEC Motors Solid	IEC Motors Split	IEC shaft diameter	IEC Frame	Plate OD
SGR-19-IEC	SGR-19-IEC-2A4	19mm	IEC 80 (2, 4, 6, 8 pole)	142mm
SGR-24-IEC	SGR-24-IEC-2A4	24mm	IEC 90S, 90L (2, 4, 6, 8 pole)	142mm
SGR-28-IEC	SGR-28-IEC-2A4	28mm	IEC 100L, 112M (2, 4, 6, 8 pole)	142mm
SGR-38-IEC	SGR-38-IEC-2A4	38mm	IEC 132S, 132M (2, 4, 6, 8 pole)	160mm
SGR-42-IEC	SGR-42-IEC-2A4	42mm	IEC 160M, 160L (2, 4, 6, 8 pole)	160mm
SGR-48-IEC	SGR-48-IEC-2A4	48mm	IEC 180M, 180L (2, 4, 6, 8 pole)	160mm
SGR-55-IEC	SGR-55-IEC-2A4	55mm	IEC 200L (2, 4, 6, 8 pole); IEC 225S, 225M (2 pole)	168mm
SGR-60-IEC	SGR-60-IEC-2A4	60mm	IEC 225S, 225M (4, 6, 8 pole); IEC 250M (2 pole)	168mm
SGR-65-IEC	SGR-65-IEC-2A4	65mm	IEC 250M (4, 6, 8 pole); IEC 280M, 280S, 315S, 315M, 315L (2 pole)	185mm
SGR-75-IEC	SGR-75-IEC-2A4	75mm	IEC 280S, 280M (4, 6, 8 pole); IEC 355M, 355L (2 pole)	193mm
SGR-80-IEC	SGR-80-IEC-2A4	80mm	IEC 315S, 315M, 315L (4, 6, 8 pole)	193mm
SGR-95-IEC	SGR-95-IEC-2A4	95mm	IEC 335L, 335M, 355L, 355M (4, 6, 8, 10 pole)	211mm

NEMA/IEC Bearing Protection Ring Kit

SOLID

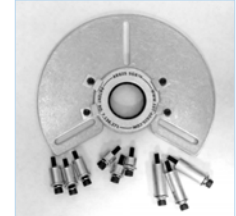

- 1 AEGIS® SGR
- 1 mounting plate
- 3 screws (inches or metric)
- 3 washers
- 3 lock washers
- 3 spacers*

SPLIT

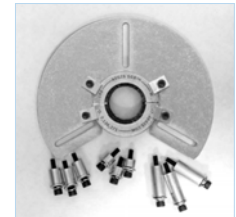

- 1 AEGIS® Split Ring SGR
- 1 split mounting plate
- 3 screws (inches or metric)
- 3 washers
- 3 lock washers
- 3 spacers*

* each kit includes 3 spacer lengths: 1/4", 1/2", and 1" for NEMA kits and 7mm, 17mm, and 27mm for IEC kits.

Mounting Plates with Hardware(no SGR)

In occasions when the shaft diameter is not one of the kitted NEMA sizes, select the correct SGR for the shaft diameter, note the SGR OD, then go to the chart below to determine the matching Mounting Plate. Plate can be used with a solid or split ring SGR.

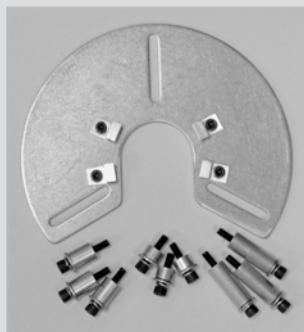

SGR sold separately

English Hardware	Fits any SGR with OD as specified
Catalog Number	SGR OD
SGR-M40-1A4	1.60" (40.6mm)
SGR-M53-1A4	2.10" (53.3mm)
SGR-M68-1A4	2.68" (68.1mm)
SGR-M78-1A4	3.10" (78.8mm)
SGR-M91-1A4	3.60" (91.4mm)
SGR-M104-1A4	4.10" (104.1mm)
SGR-M116-1A4	4.60" (116.8mm)
SGR-M129-1A4	5.10" (129.5mm)
SGR-M142-1A4	5.60" (142.2mm)
SGR-M154-1A4	6.10" (154.9mm)
SGR-M167-1A4	6.60" (167.6mm)
SGR-M180-1A4	7.10" (180.3mm)

Kit includes (1) mounting plate,
 (3) 1/4" spacers with screws and washers
 (3) 1/2" spacers with screws and washers
 (3) 1" spacers with screws and washers

Metric Hardware	Fits any SGR with OD as specified
Catalog Number	SGR OD
SGR-M40-2A4	1.60" (40.6mm)
SGR-M53-2A4	2.10" (53.3mm)
SGR-M68-2A4	2.68" (68.1mm)
SGR-M78-2A4	3.10" (78.8mm)
SGR-M91-2A4	3.60" (91.4mm)
SGR-M104-2A4	4.10" (104.1mm)
SGR-M116-2A4	4.60" (116.8mm)
SGR-M129-2A4	5.10" (129.5mm)
SGR-M142-2A4	5.60" (142.2mm)
SGR-M154-2A4	6.10" (154.9mm)
SGR-M167-2A4	6.60" (167.6mm)
SGR-M180-2A4	7.10" (180.3mm)

Kit includes (1) mounting plate,
 (3) 7mm spacers with screws and washers
 (3) 17mm spacers with screws and washers
 (3) 27mm spacers with screws and washers

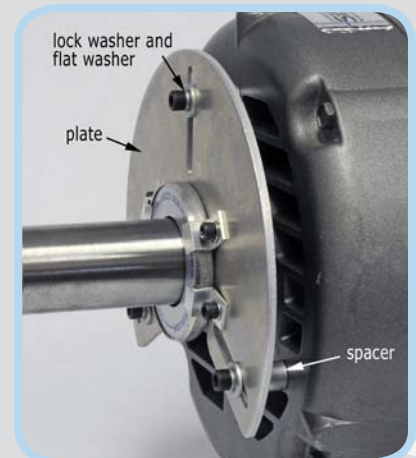



AEGIS® SVP Shaft Voltage Probe Kits Conductive Microfiber tips for use with Fluke 190 Series II ScopeMeter®

For the first time you can easily and more accurately measure the voltage on a rotating shaft. The AEGIS® SVP Shaft Voltage Probe's unique design of high density conductive microfibers ensures continuous contact with the rotating shaft. Used with the Fluke 190 Series II ScopeMeter, you can determine if your motor is subject to potentially damaging bearing currents. Visit our website for a complete part list.

Catalog Number	Includes:
SVP-KIT-3000MB	3 SVP tips, probe holder with two piece extension rod (total length of probe holder with extension rod is 18 inches) and magnetic base.
SVP-KIT-3000	3 SVP tips, probe holder with two piece extension rod (total length of probe holder with extension rod is 18 inches).
SVP-TIP-3000	3 SVP replacement tips only

Fits Fluke VPS410 Voltage Probe. For other probe styles, see website.

Installation: Pull off the hook clip from the voltage probe. Install the SVP tip over the voltage probe tip until seated against the probe shoulder. Secure with plastic screw. Do not over tighten screw.

Note: 10:1 probe not included
Magnetic base not sold separately



AEGIS® Colloidal Silver Shaft Coating

Catalog Number	Coverage:
CS015	20-25 applications based on a 3" shaft diameter

Used to improve the conductivity of the steel shaft surface. Apply to any VFD driven motor shaft prior to installing the AEGIS® Bearing Protection Ring.

Note: Shelf life is 6 months



AEGIS® Conductive Epoxy

Catalog Number	Coverage:
EP2400	2-3 applications

Used to install the AEGIS® Bearing Protection Ring without drilling and tapping into the motor end bell.

Note: Shelf life is 9 months



Engineering Specification:

All motors operated on variable frequency drives shall be equipped with a maintenance free, conductive micro fiber, shaft grounding ring with a minimum of two rows of circumferential micro fibers to discharge electrical shaft currents within the motor and/or its bearings.

Application Note: Motors up to 100HP shall be provided with a minimum of one shaft grounding ring installed either on the drive end or non-drive end. Motors over 100HP shall be provided with an insulated bearing on the non-drive end and a shaft grounding ring on the drive end of the motor. Grounding rings shall be provided and installed by the motor manufacturer or contractor and shall be installed in accordance with the manufacturer's recommendations.

Recommended part: AEGIS® SGR Bearing Protection Ring

WARRANTY: Units are guaranteed for one year from date of purchase against defective materials and workmanship. Replacement will be made except for defects caused by abnormal use or mishandling. All statements and technical information contained herein, or presented by the manufacturer or his representative are rendered in good faith. User must assume responsibility to determine suitability of the product for intended use. The manufacturer shall not be liable for any injury, loss or damage, direct or consequential arising out of the use, or attempt to use the product.

Patent Numbers: 7,136,271; 7,193,836; and other patents pending



www.est-aegis.com





BEARING PROTECTION RING



Electro Static Technology™
An ITW Company

31 Winterbrook Road
Mechanic Falls, Maine 04256
Tel.: 866-738-1857
Fax: 207-998-5143
www.est-aegis.com

Catalog No. 2012-1



NEW
Split uKIT



AEGIS® SGR uKIT Bearing Protection Ring with Universal Mounting Brackets

AEGIS® SGR - Electrical Bearing Damage Protection™

The new AEGIS® Shaft Grounding Ring Kit with universal mounting brackets allows universal mounting options to fit almost any motor design in the NEMA frames from 56 to 449T. The AEGIS® SGR uKIT includes:

- AEGIS® Bearing Protection Ring designed for the motor's NEMA "u" dimension - shaft diameter
- Solid and Split Ring designs
- Four mounting bracket styles and hardware to adapt the AEGIS® ring to virtually any end bracket
- Screw on or AEGIS® Conductive Epoxy Adhesive mounting capable (Epoxy EP2400 sold separately)
- Fits over slingers, seals or shaft shoulders

PROBLEM

Without an AEGIS® Bearing Protection Ring, induced shaft voltages cause destructive bearing currents that can lead to catastrophic "fluting" damage, decrease bearing lubrication life, and premature motor failure.



SOLUTION

The AEGIS® Bearing Protection Ring dramatically extends motor service life by safely channeling harmful VFD induced shaft voltages away from the motor's bearings to ground.



Learn more about protecting motors from VFD-induced bearing damage at:

www.est-aegis.com

Patented Technology

TECHNICAL DATA FOR SOLID AND SPLIT RING uKIT DESIGNS

AEGIS® SGR uKit for NEMA Motors Includes:

- (1) AEGIS® SGR Bearing Protection Ring
- (4) Universal bracket sets
- (4) 5-40 x 3/8" flat head screws
- (4) 6-32 x 3/8" socket head cap screws
- (4) #6 split lock washers
- (4) #6 flat washers
- 5/64" allen wrench
- 7/64" allen wrench

Tools required for installation:

- #36 drill
- #6-32 tap
- Fine grit emery cloth/sand paper
- CS015 AEGIS® Colloidal Silver Shaft Coating (recommended)

SOLID RING ONLY Motor with 3 hole bracket pattern

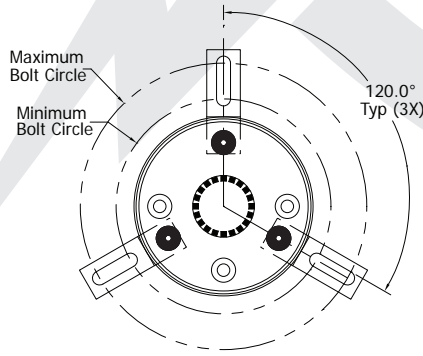

SOLID AND SPLIT RING Motor with 4 hole bracket pattern

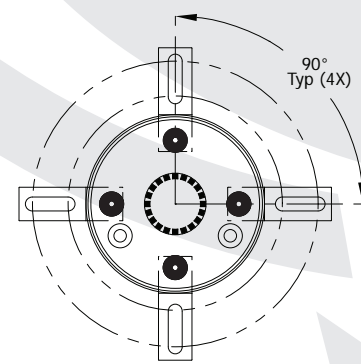

Tools for Conductive Epoxy Installation

- EP2400 AEGIS® Conductive Epoxy
- Dremel tool for removing paint on motor end bracket
- Heat gun to expedite curing time of conductive epoxy



Shaft	Min Circle	Max Circle
0.625"	2.400"	3.200"
0.875"	2.650"	3.450"
1.125"	2.900"	3.700"
1.375"	3.150"	3.950"
1.625"	3.400"	4.200"
1.875"	3.650"	4.450"
2.125"	3.900"	4.700"
2.375"	4.150"	4.950"
2.875"	4.650"	5.450"
3.375"	5.150"	5.950"
3.625"	5.400"	6.200"
3.875"	5.650"	6.450"
4.375"	6.150"	6.950"
4.875"	6.650"	7.450"

Shaft	Min Circle	Max Circle
0.625"	3.700"	5.375"
0.875"	3.950"	5.625"
1.125"	4.200"	5.875"
1.375"	4.450"	6.125"
1.625"	4.700"	6.375"
1.875"	4.950"	6.625"
2.125"	5.200"	6.875"
2.375"	5.450"	7.125"
2.875"	5.950"	7.625"
3.375"	6.450"	8.125"
3.625"	6.700"	8.375"
3.875"	6.950"	8.625"
4.375"	7.450"	9.125"
4.875"	7.950"	9.625"

Shaft	Min Circle	Max Circle
0.625"	4.575"	5.375"
0.875"	4.825"	5.625"
1.125"	5.075"	5.875"
1.375"	5.325"	6.125"
1.625"	5.575"	6.375"
1.875"	5.825"	6.625"
2.125"	6.075"	6.875"
2.375"	6.325"	7.125"
2.875"	6.825"	7.625"
3.375"	7.325"	8.125"
3.625"	7.575"	8.375"
3.875"	7.825"	8.625"
4.375"	8.325"	9.125"
4.875"	8.825"	9.625"

Mounting bolt circle is the same for 3 or 4 brackets

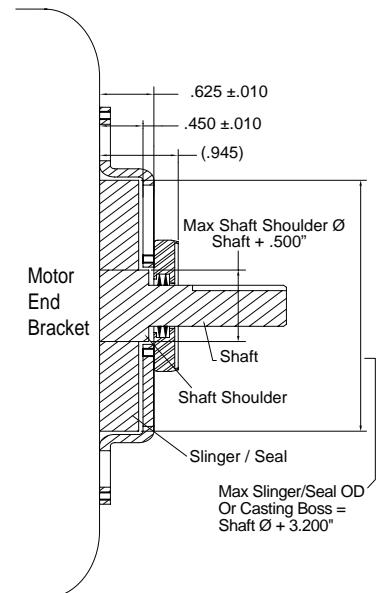
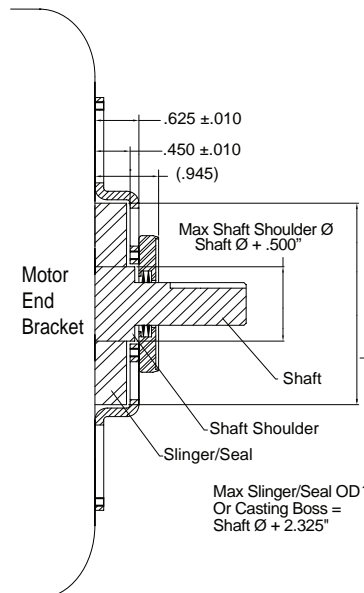
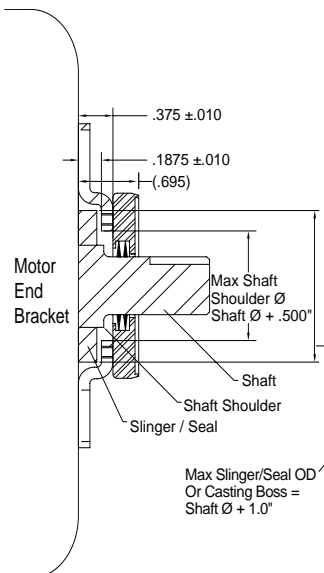

TECHNICAL DATA FOR SOLID AND SPLIT RING uKIT DESIGNS

Installation Guide:

1. Shaft must be clean & free of any coatings, paint, or other nonconductive material.

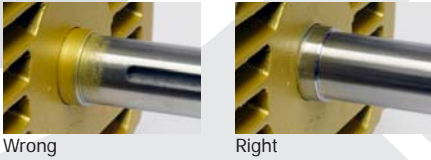

2. AEGIS® SGR should not operate over a keyway. If SGR will operate over a keyway, fill keyway with a fast-curing epoxy putty (such as Devcon epoxy putty) in the area of contact.
3. Select the bracket size based on the clearance needed from the end bracket/slinger/shaft shoulder. For solid ring, choose either a 3 hole or 4 hole bracket pattern, for split ring attach 4 brackets. Attach brackets to the AEGIS® ring using the 5-40 x 3/8" flat head screws.
4. Install the AEGIS® SGR so that the aluminum ring maintains an even clearance around the shaft. Conductive MicroFibers™ must be in contact with the conductive metal surface of the shaft. Mark your bracket locations.
5. To increase the conductivity of the shaft we recommend applying a light

coat of the AEGIS® Colloidal Silver Shaft Coating PN CS015 to the shaft area where the AEGIS® microfibers are in contact with the motor shaft. Apply evenly all around the shaft.

6. Prepare Motor End Bracket for installation with screws:
 - a. Drill (3 or 4) holes using a #36 drill. Avoid drilling into bearing.
 - b. Depth of hole should be 1/4"
 - c. Tap each hole with a #6-32 tap
 - d. Install the uKIT and secure to the motor with the hardware provided. The bolts provide the path to ground. Do not use Loctite© or any other non-conductive material to secure the screws.
7. *Easy Option* Conductive Epoxy Installation (AEGIS® Conductive Epoxy EP2400 sold separately):
 - a. Remove paint on the motor end bracket where the AEGIS® uKIT brackets will be attached. These areas must be clean & free of any coatings, paint, or other nonconductive material.
 - b. Prepare conductive epoxy per package directions
 - c. Apply the epoxy to the Universal brackets
 - d. Install the uKIT. Hold the uKIT in place until epoxy is firmly holding. Allow epoxy to cure for 4 hrs at or above 75°F. For quickest curing time, use a heat gun to heat epoxy for 10 minutes, then allow to cool.



Shaft	Min Circle	Max Circle
0.625"	2.450"	4.325"
0.875"	2.700"	4.575"
1.125"	2.950"	4.825"
1.375"	3.200"	5.075"
1.625"	3.450"	5.325"
1.875"	3.700"	5.575"
2.125"	3.950"	5.825"
2.375"	4.200"	6.075"
2.875"	4.700"	6.575"
3.375"	5.200"	7.075"
3.625"	5.450"	7.325"
3.875"	5.700"	7.575"
4.375"	6.200"	8.075"
4.875"	6.700"	8.575"

Shaft	Min Circle	Max Circle
0.625"	3.700"	5.375"
0.875"	3.950"	5.625"
1.125"	4.200"	5.875"
1.375"	4.450"	6.125"
1.625"	4.700"	6.375"
1.875"	4.950"	6.625"
2.125"	5.200"	6.875"
2.375"	5.450"	7.125"
2.875"	5.950"	7.625"
3.375"	6.450"	8.125"
3.625"	6.700"	8.375"
3.875"	6.950"	8.625"
4.375"	7.450"	9.125"
4.875"	7.950"	9.625"

Shaft	Min Circle	Max Circle
0.625"	4.575"	5.375"
0.875"	4.825"	5.625"
1.125"	5.075"	5.875"
1.375"	5.325"	6.125"
1.625"	5.575"	6.375"
1.875"	5.825"	6.625"
2.125"	6.075"	6.875"
2.375"	6.325"	7.125"
2.875"	6.825"	7.625"
3.375"	7.325"	8.125"
3.625"	7.575"	8.375"
3.875"	7.825"	8.625"
4.375"	8.325"	9.125"
4.875"	8.825"	9.625"

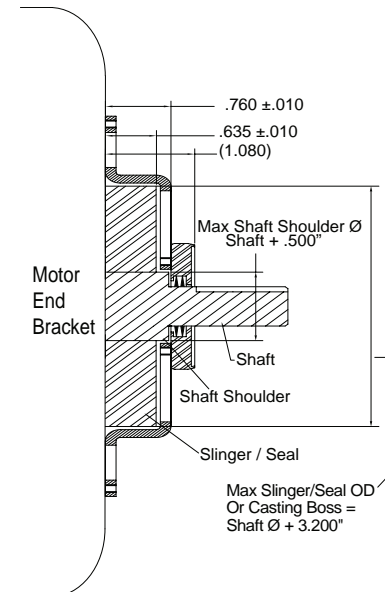
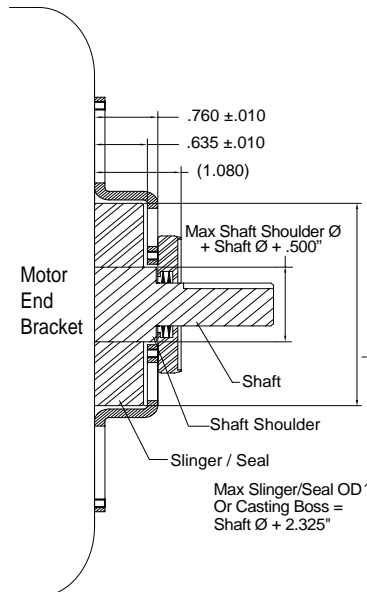
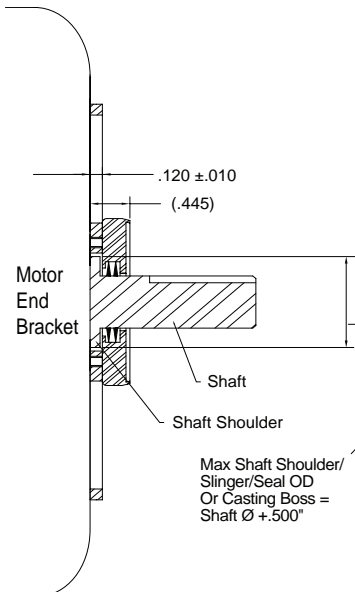



Solid

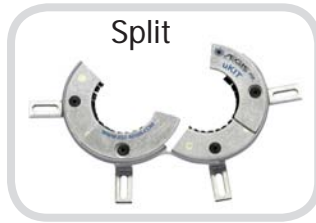

Split

Includes four mounting bracket styles and hardware to adapt the AEGIS® ring to virtually any end bracket.



uKIT Catalog Number Solid Ring	uKIT Catalog Number Split Ring	Motor shaft diameter "u"	NEMA Frame
SGR-0.625-UKIT	SGR-0.625-UKIT-1A4	0.625"	56
SGR-0.875-UKIT	SGR-0.875-UKIT-1A4	0.875"	143T, 145T
SGR-1.125-UKIT	SGR-1.125-UKIT-1A4	1.125"	182T, 184T
SGR-1.375-UKIT	SGR-1.375-UKIT-1A4	1.375"	213T, 215T
SGR-1.625-UKIT	SGR-1.625-UKIT-1A4	1.625"	254T, 256T, 284TS, 286TS
SGR-1.875-UKIT	SGR-1.875-UKIT-1A4	1.875"	284T, 286T, 324TS, 326TS, 364TS, 365TS
SGR-2.125-UKIT	SGR-2.125-UKIT-1A4	2.125"	324T, 326T, 404TS, 405TS
SGR-2.375-UKIT	SGR-2.375-UKIT-1A4	2.375"	364T, 365T, 444TS, 445TS, 447TS, 449TS
SGR-2.875-UKIT	SGR-2.875-UKIT-1A4	2.875"	404T, 405T
SGR-3.375-UKIT	SGR-3.375-UKIT-1A4	3.375"	444T, 445T, 447T, 449T
SGR-3.625-UKIT	SGR-3.625-UKIT-1A4	3.625"	
SGR-3.875-UKIT	SGR-3.875-UKIT-1A4	3.875"	
SGR-4.375-UKIT	SGR-4.375-UKIT-1A4	4.375"	
SGR-4.875-UKIT	SGR-4.875-UKIT-1A4	4.875"	

Optional		
EP2400		AEGIS® Conductive Epoxy 2-3 applications. Used to install AEGIS® SGR without drilling and tapping into the motor end bell.
CS015		AEGIS® Colloidal Silver Shaft Coating 20-25 applications based on a 3" shaft diameter. Used to improve the conductivity of the steel shaft surface. Apply to any VFD driven motor shaft prior to installing the AEGIS® SGR.

Features and Benefits

- Protects both motor bearings and the bearings in attached equipment
- Channels harmful currents to ground
- Mounting brackets to fit virtually any motor
- Order the AEGIS® SGR based on the motor "u" dimension, clears slinger or shaft shoulder.
- Improves system reliability; maintenance-free
- Flexible 3 or 4 bracket mounting design